

LAYOUT DRILLING MACHINE FMB EXPLORER 1

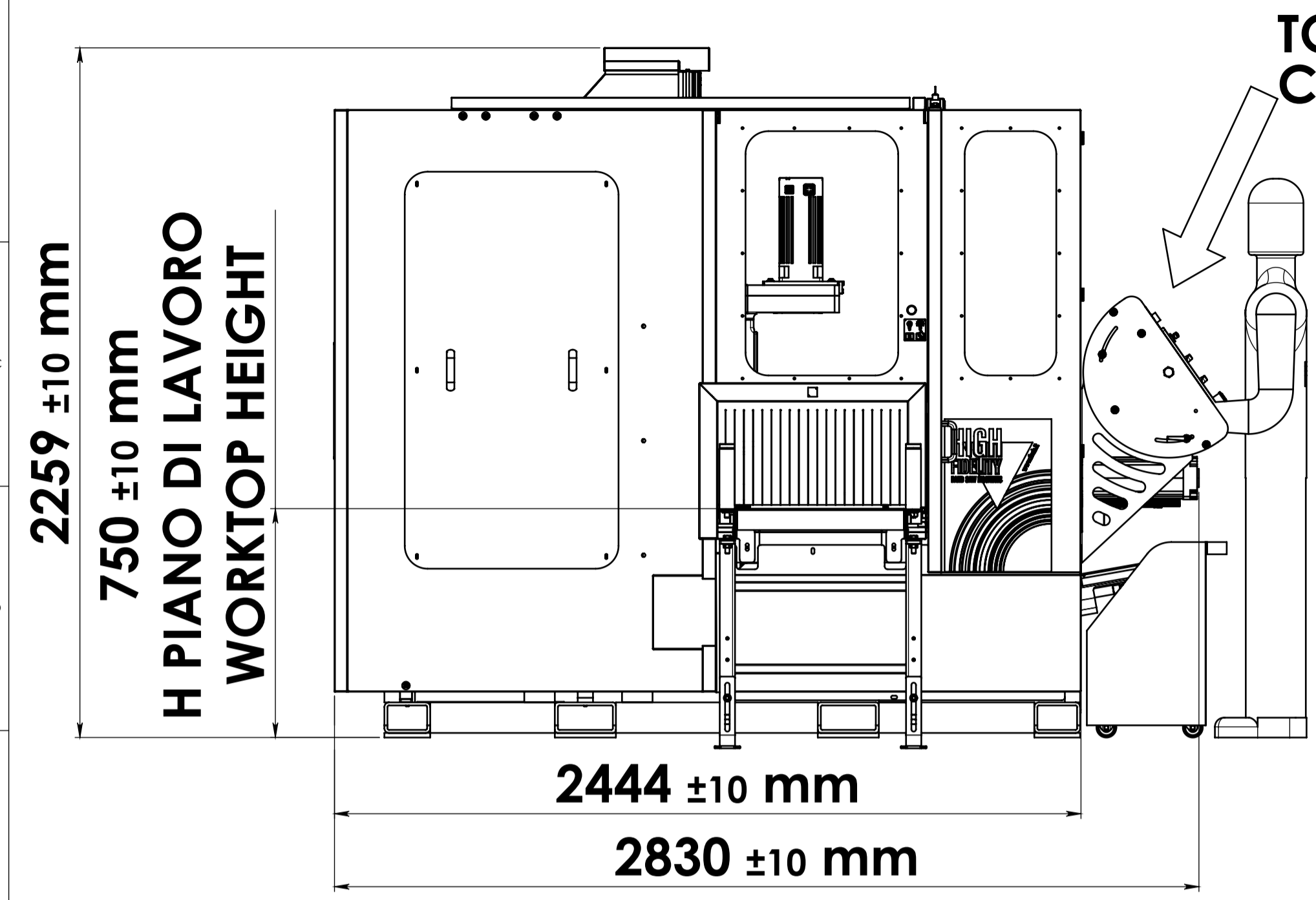

TOUCH SCREEN
CONTROL PANEL

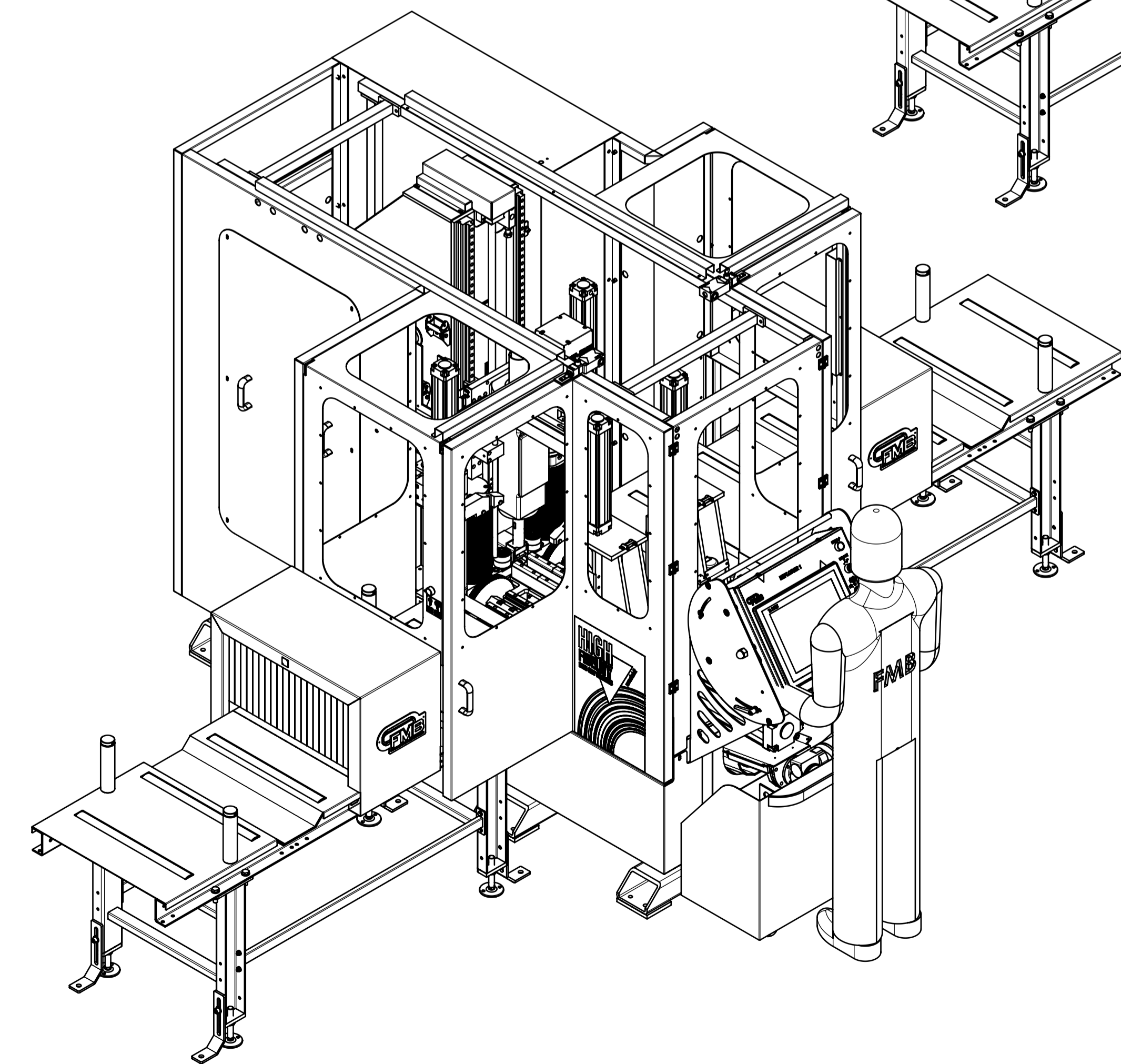
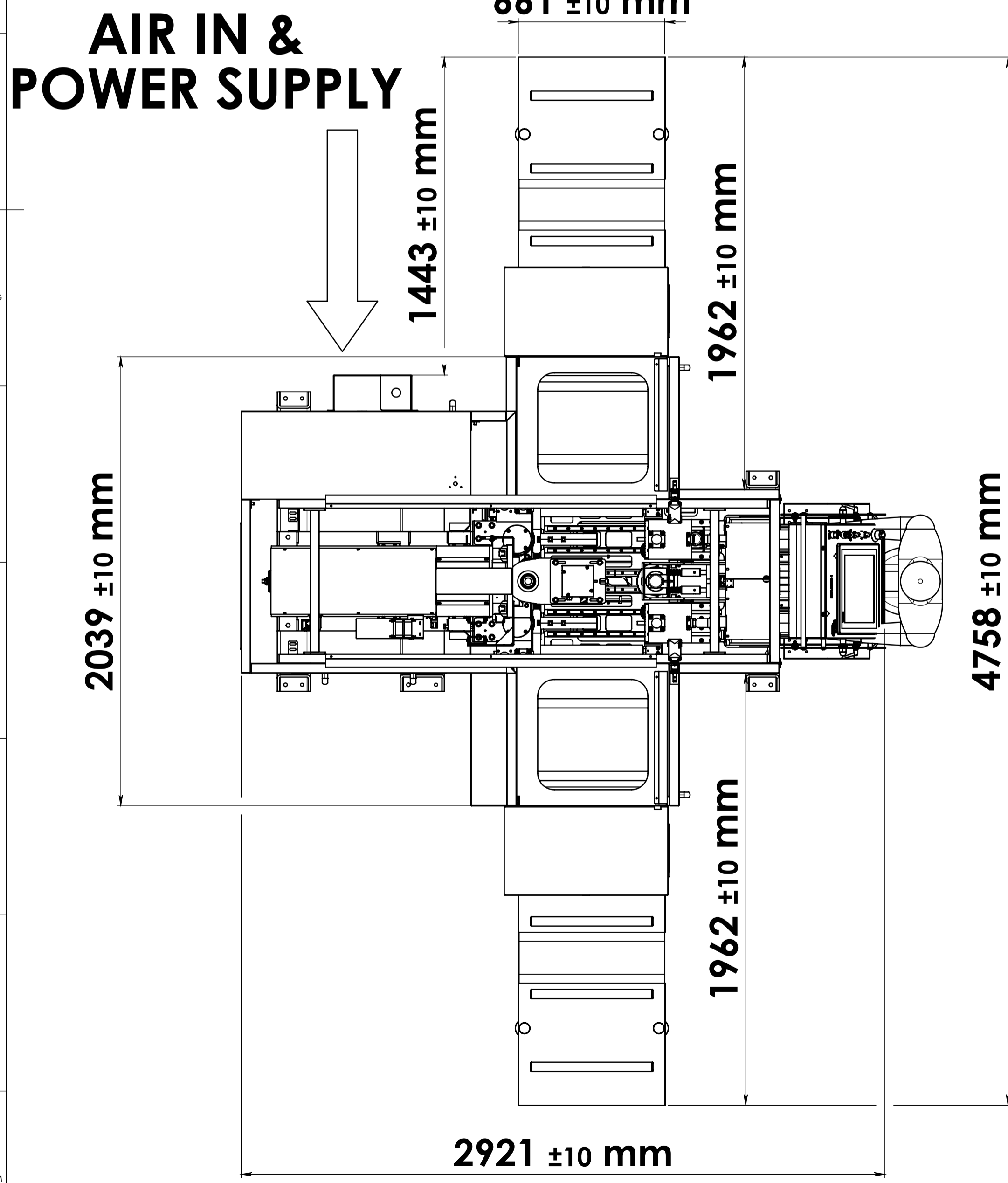
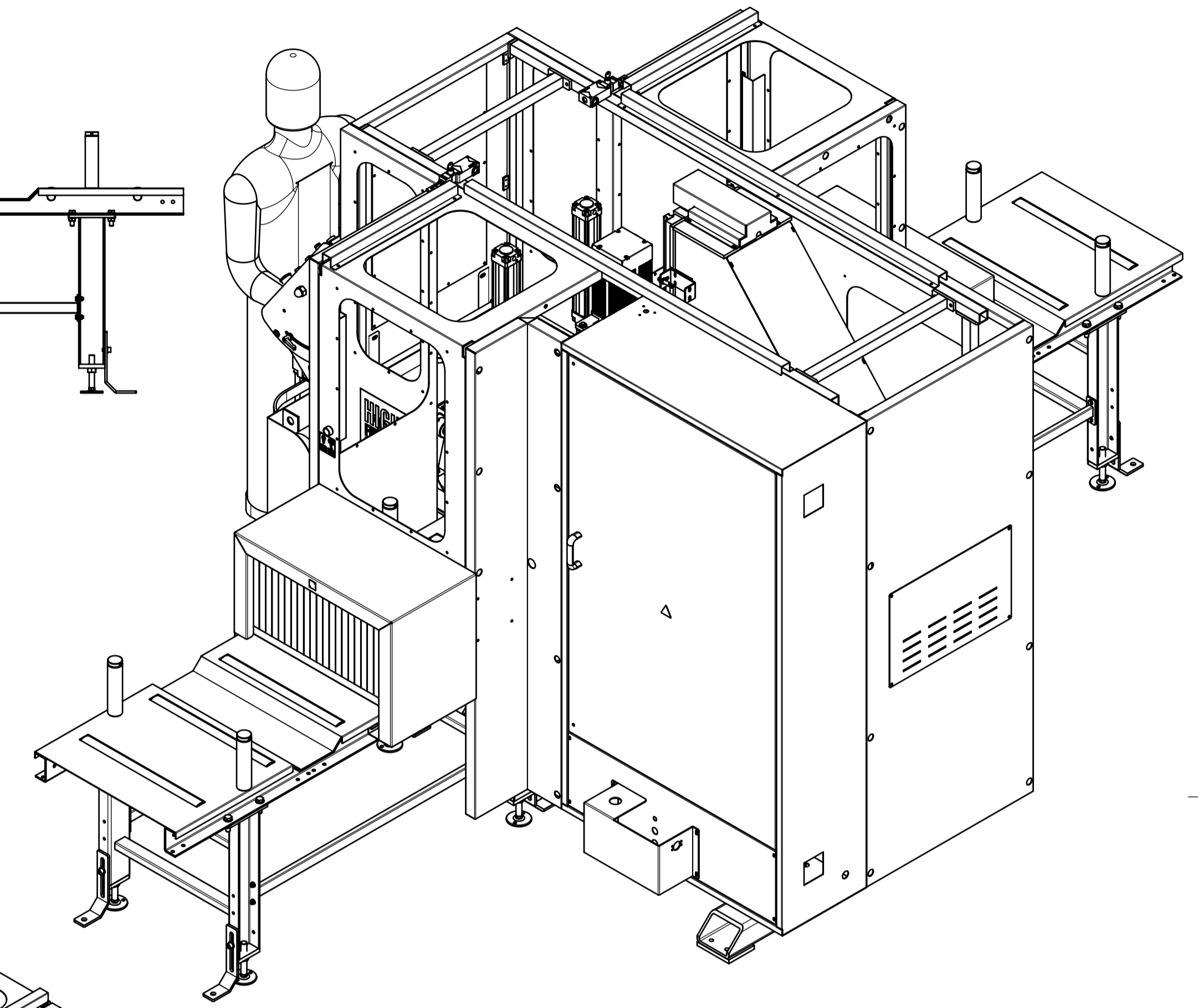
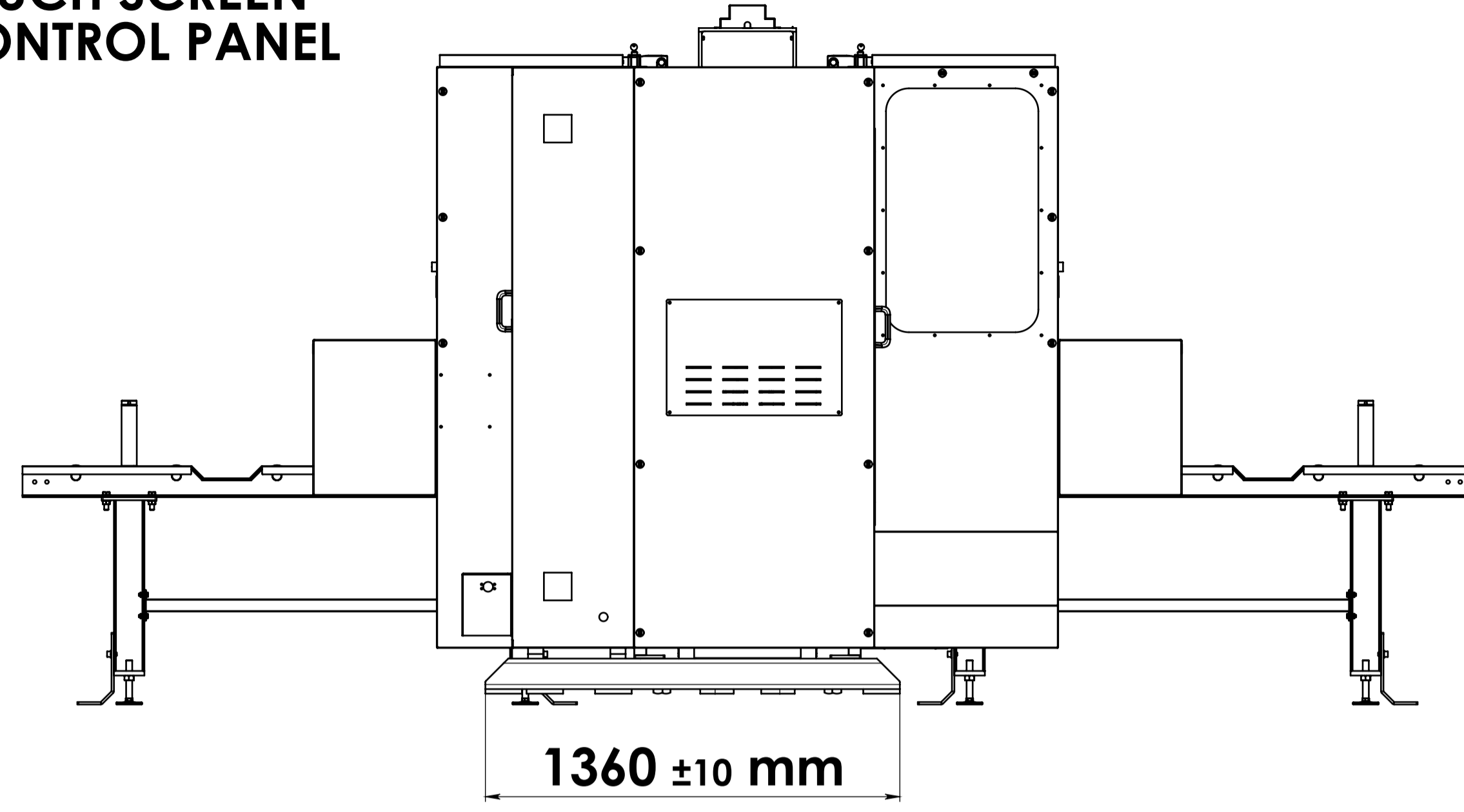

STATO DISEGNO		DESCRIZIONE OGGETTO REVISIONE		ESECUTORE
REV. N°	DATA	MATERIALE	FINITURA SUPERFICIALE	TRATT. TERMICO
DISEGNATO		OGGETTO: DRILLING MACHINE EXPLORER 1		
DATA DISEGNO		PARTICOLARE: DRILLING MACHINE EXPLORER 1		
26-11-2014		SCALA: 1:16 A1		
MODELLATO	DATA MODELLO	DISEGNO N°	VOLUME SUPERFICIE SURFACE	
			12,5/ Grezzo To Rough	3,2/ Finito Finish
Scostamenti limite ammessi per dimensioni lineari UNI ISO 2768/F		0,8/ Rettificato Grinding		MASSAWEIGHT
Value of tolerance linear dimensions UNI ISO 2768/F		Quote senza indicazione di tolleranza - Dimensions without indications of tolerance		
±0.05	±0.05	±0.1	±0.15	±0.2
±0.05	±0.05	±0.1	±0.15	±0.2
IL PRESENTE DISEGNO E' DI ESCLUSIVA PROPRIETA' DELLA F.M.B. E PERTANTO NE E' VIETATA LA RIPRODUZIONE ANCHE PARZIALE SENZA LA SUA AUTORIZZAZIONE SCRITTA.				