

# LAYOUT SATURN+G

2074 ±10 mm

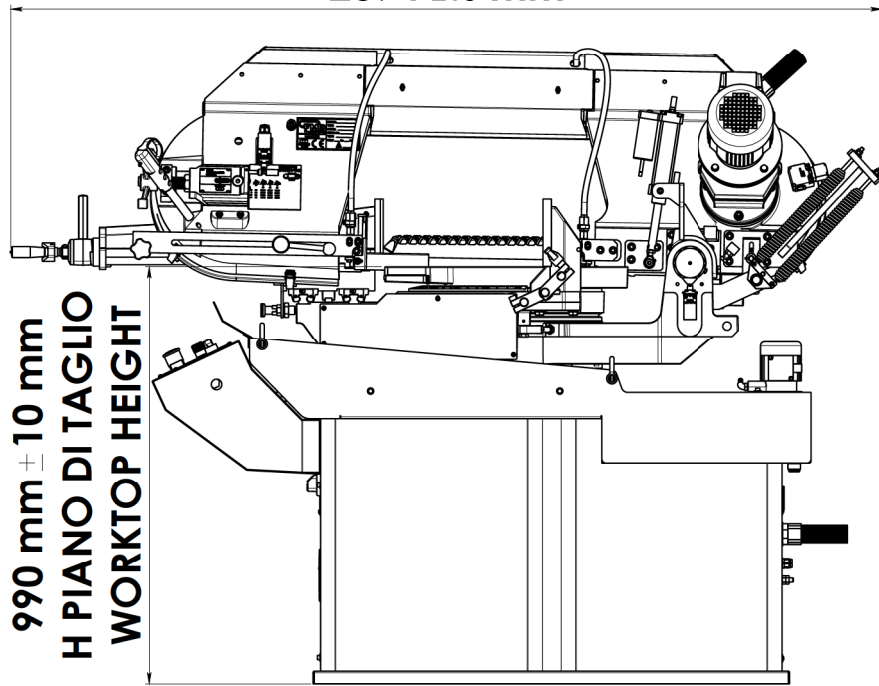

990 mm ± 10 mm  
H PIANO DI TAGLIO  
WORKTOP HEIGHT

1517 ±10 mm

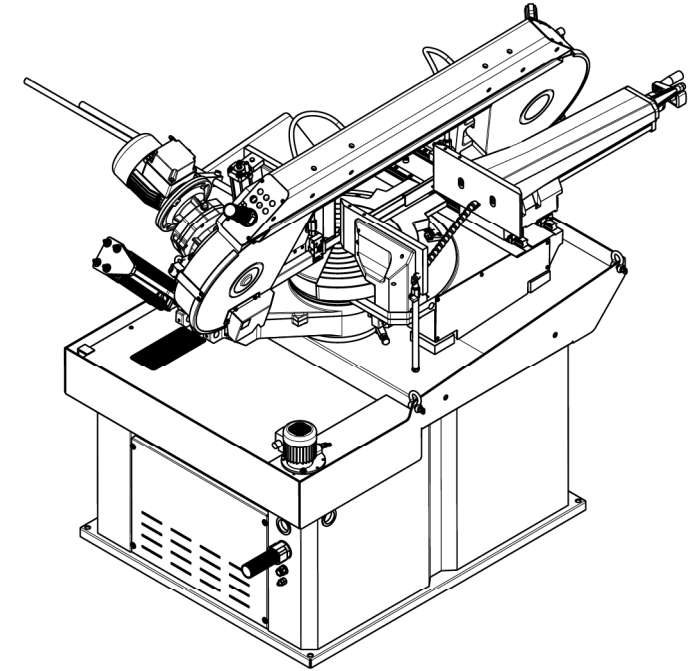
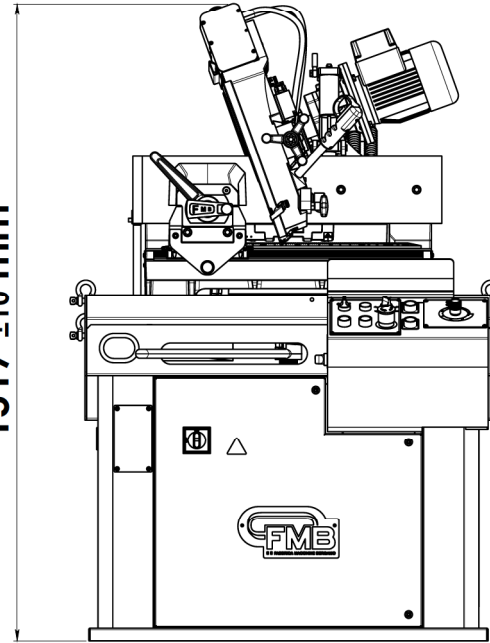

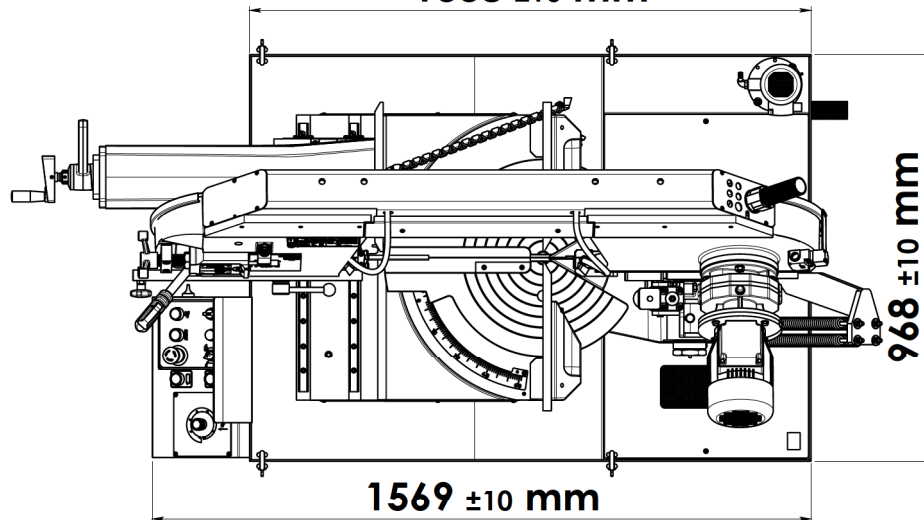

1338 ±10 mm

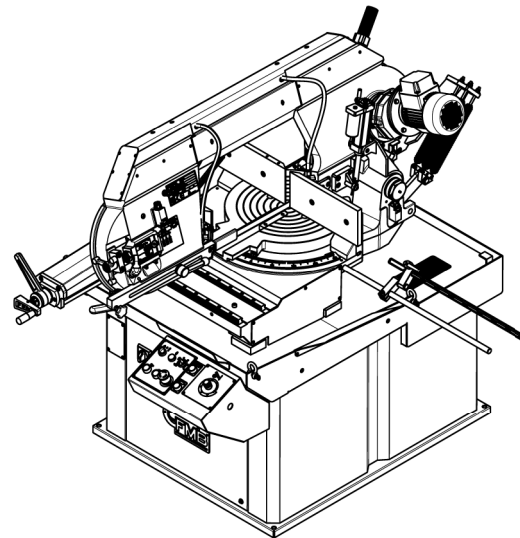

968 ±10 mm

1569 ±10 mm



STATO DISEGNO		DESCRIZIONE OGGETTO		REVISIONE		ESECUTORE	
REV. N°	DATA						
MATERIALE		FINITURA SUPERFICIALE		TRATT. TERMICO			
 FABBRICA MACCHINE BERGAMO		OGGETTO: LAYOUT SATURN+G					
DISEGNATO	DATA DISEGNO	SCALA	DISEGNO N°				
MODELLATO	DATA MODELLO	1:9	A2				
		<input checked="" type="checkbox"/> Grezzo Rough	<input type="checkbox"/> 12,5/ Sgrossato To Rough	<input type="checkbox"/> 3,2/ Finito Finish	<input type="checkbox"/> 0,8/ Rettificato Grinding		
Scostamenti limite ammessi per dimensioni lineari UNI ISO 2788/F Value of tolerance linear dimensions UNI ISO 2788/F Guardie senza indicazioni di tolleranza - Dimensions without indications of tolerance							
0.5-3	±0.05	±0.05	±0.1	±0.15	±0.2	±0.3	±0.5
VOLUME SUPERFICIE							FOGLIO 1 DI 1
IL PRESENTE DISEGNO E' DI ESCLUSIVA PROPRIETA' DELLA F.M.B. E PERTANTO NE E' VIETATA LA RIPRODUZIONE ANCHE PARZIALE SENZA LA SUA AUTORIZZAZIONE SCRITTA.							