

# LAYOUT PEGASUS XL

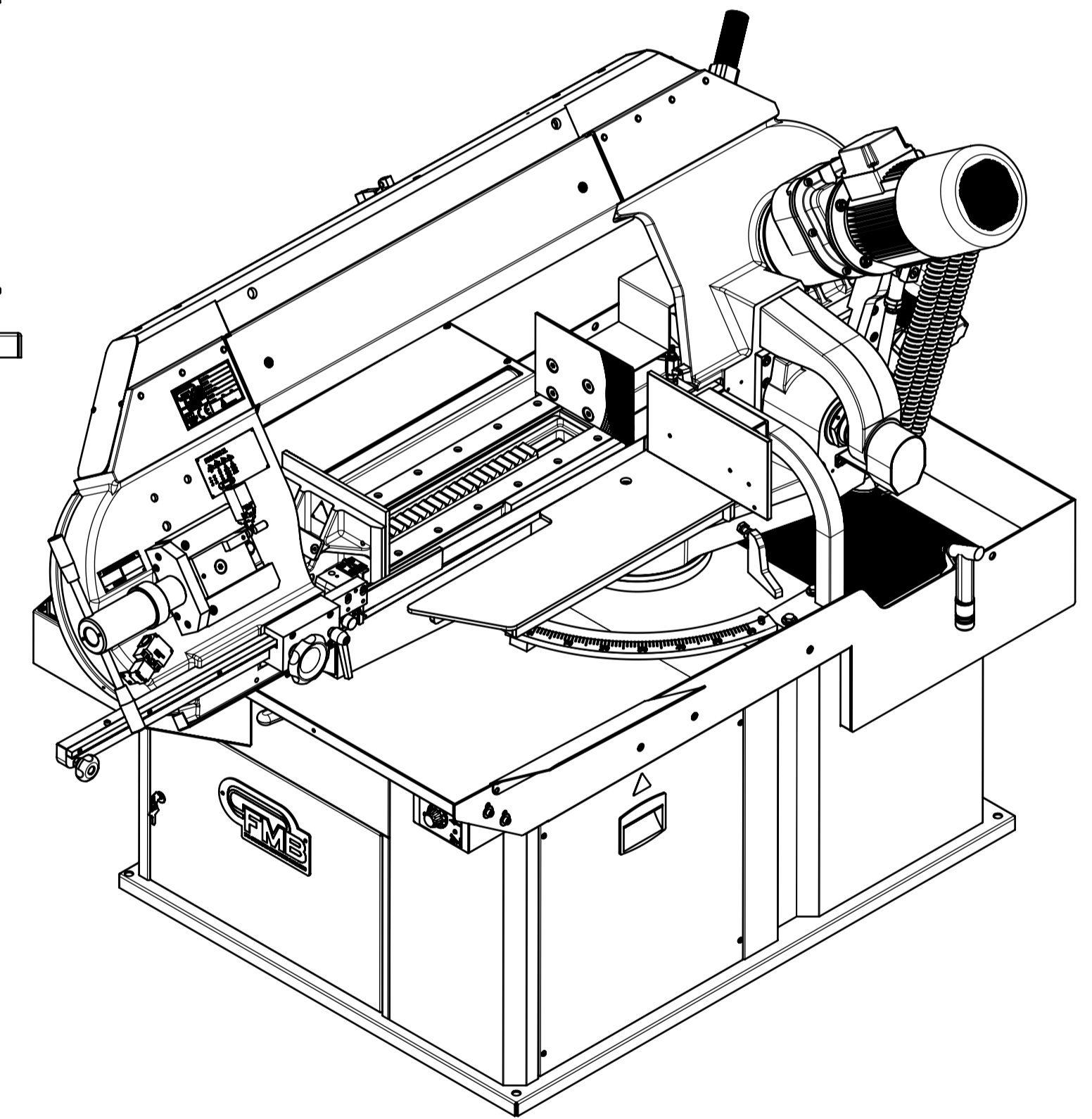
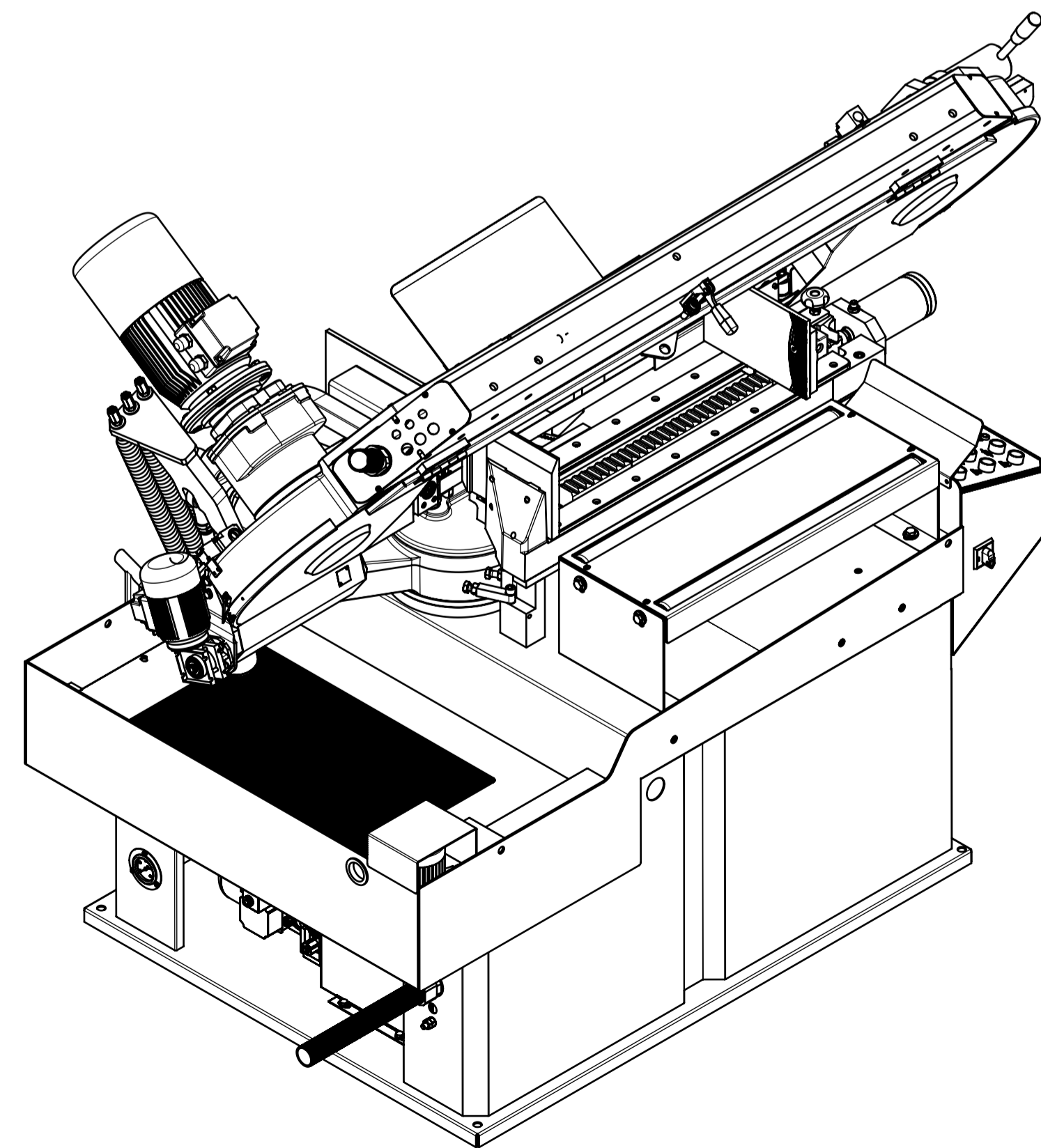
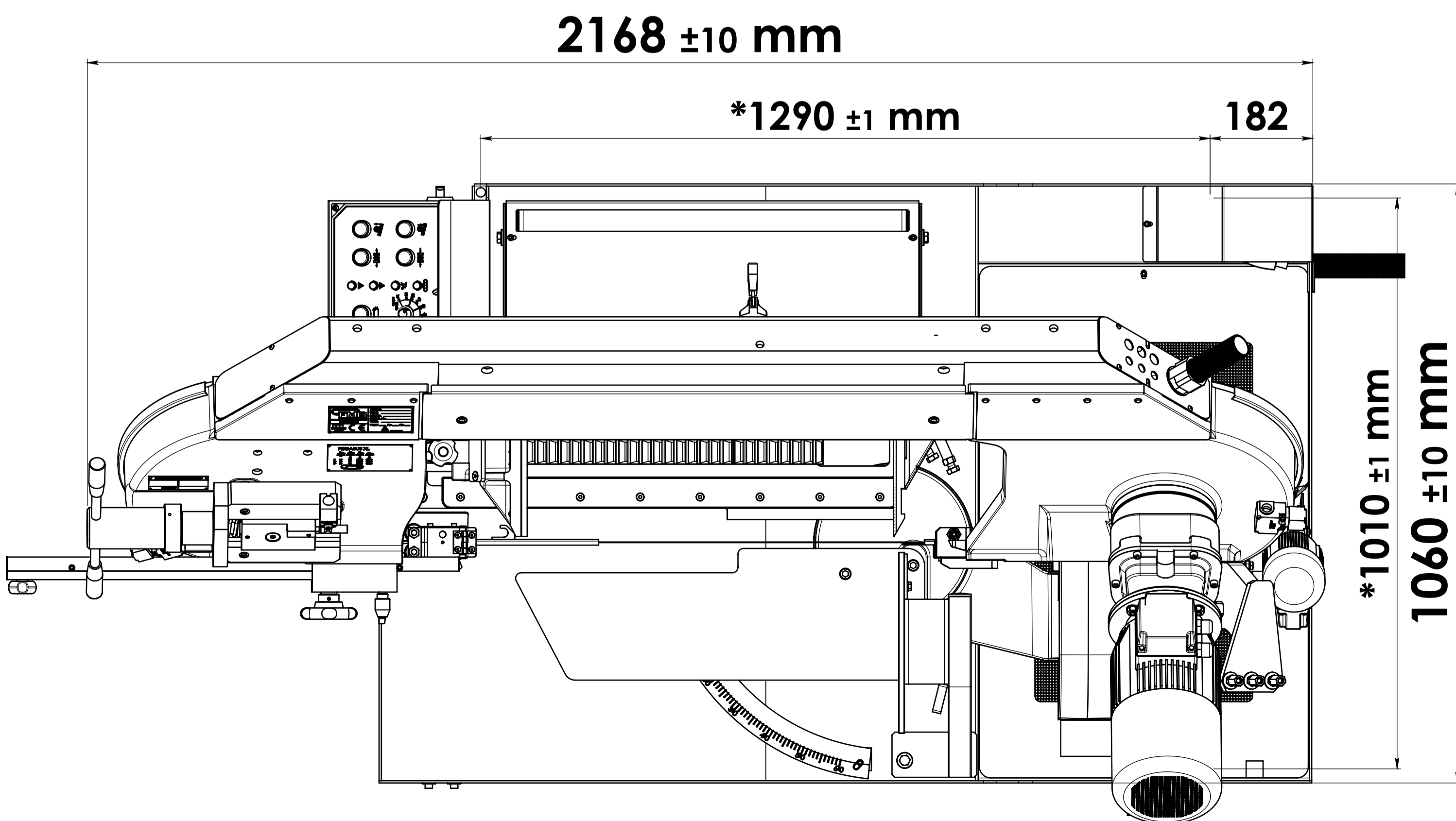
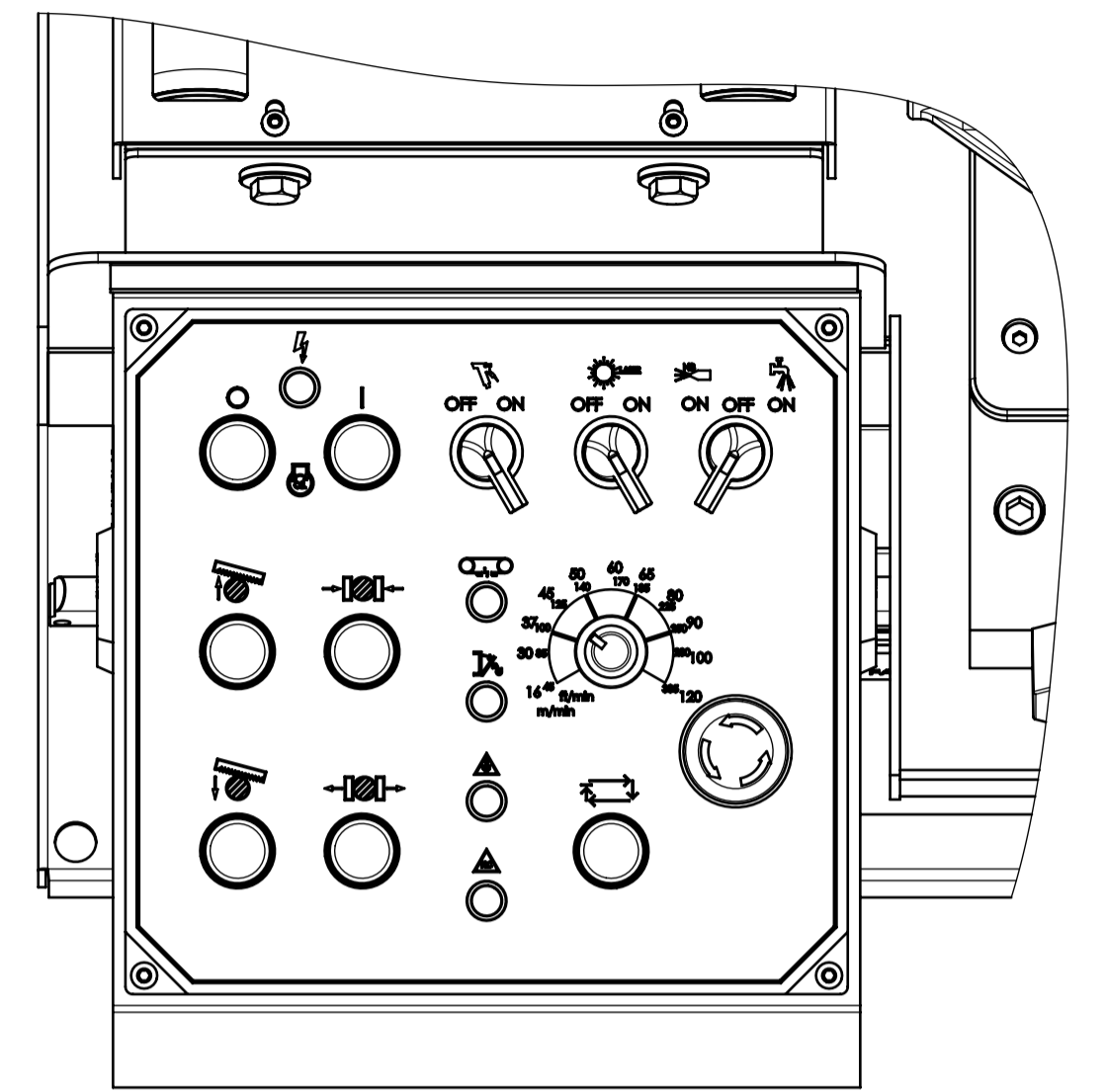
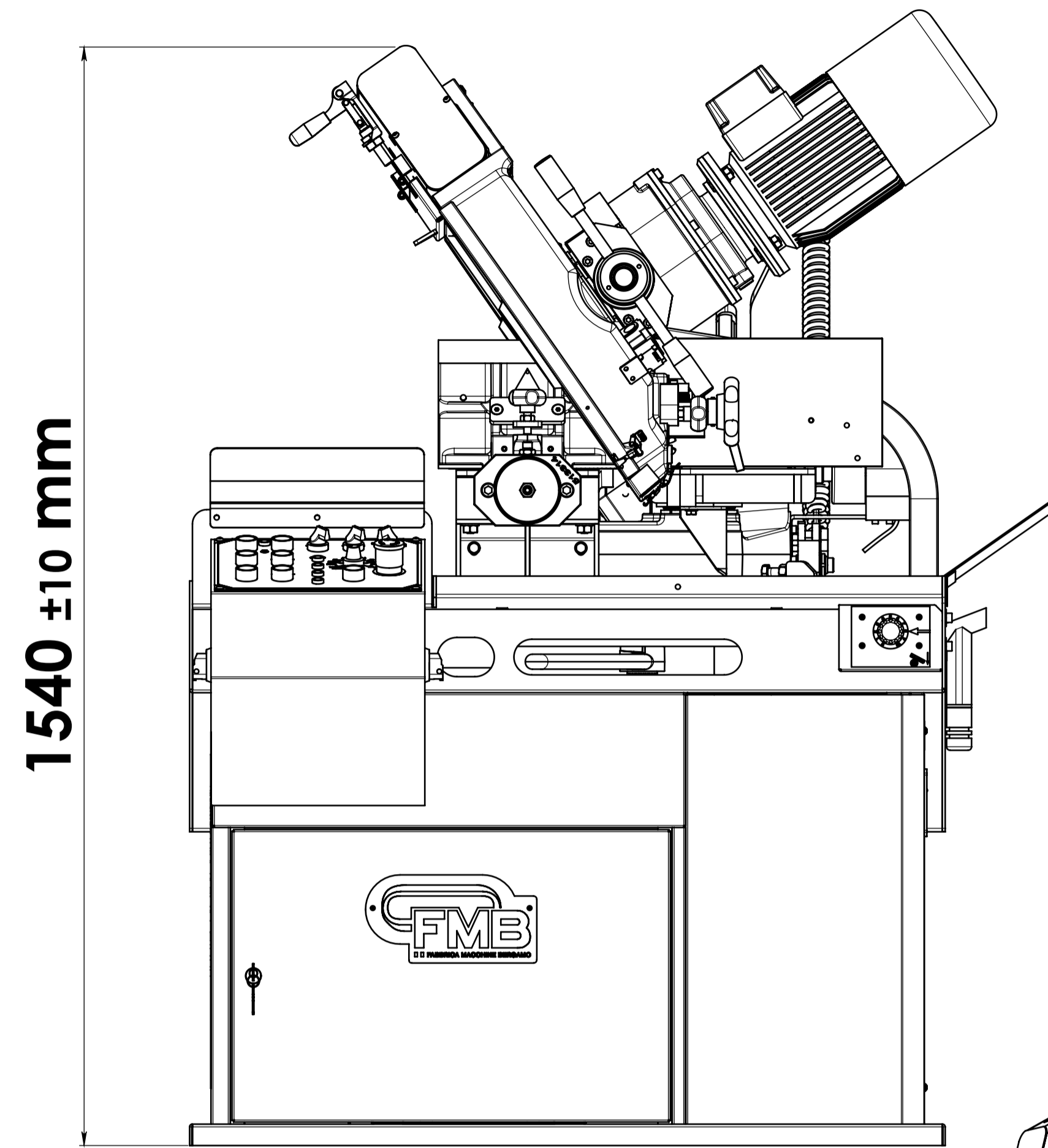
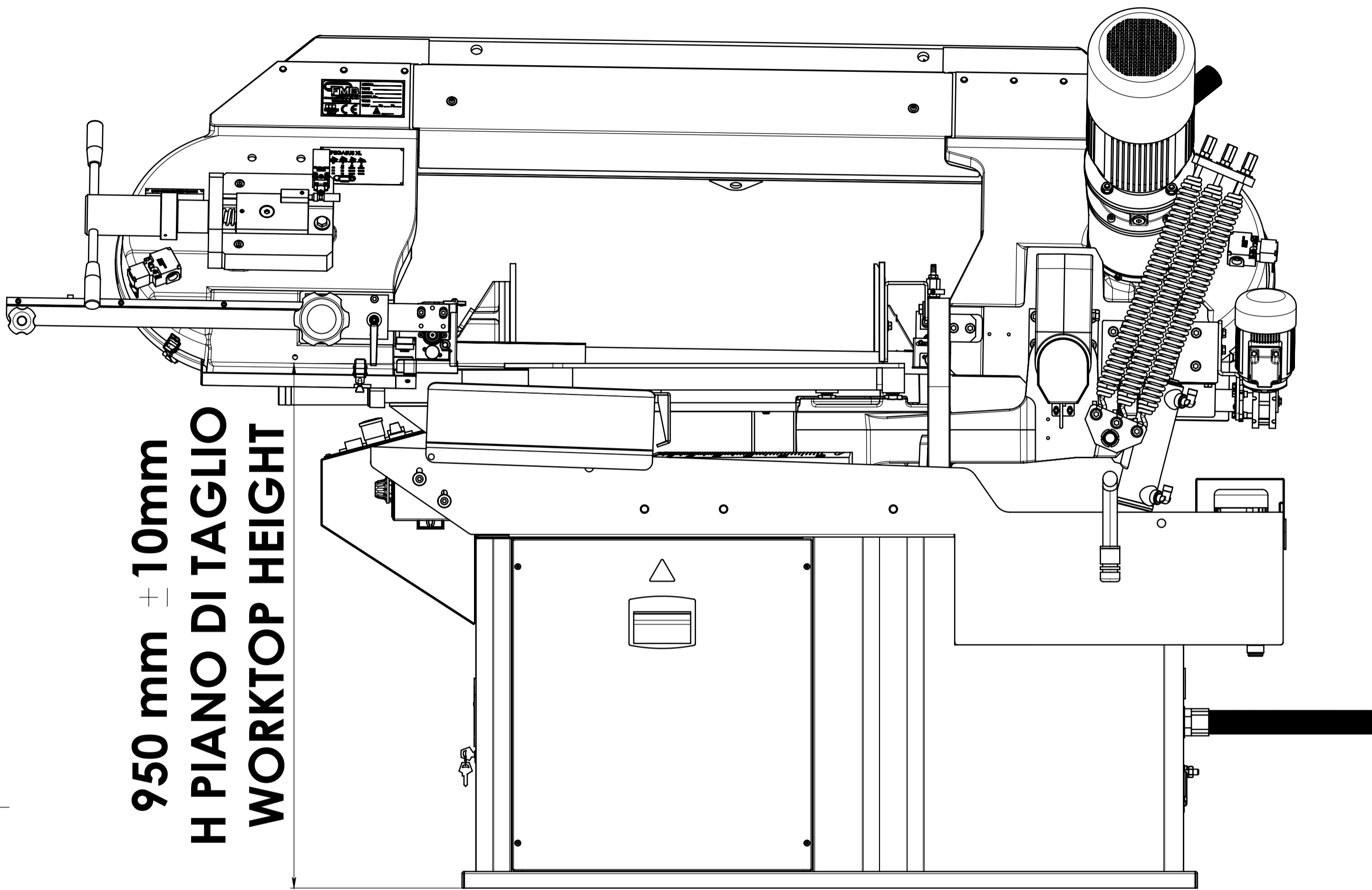

STATO DISEGNO		DESCRIZIONE OGGETTO REVISIONE		ESECUTORE
REV. N°	DATA	MATERIALE	FINITURA SUPERFICIALE	TRATT. TERMICO
DISEGNATO		OGGETTO:		
DATA DISEGNO		PARTICOLARE: PEGASUS XL		
MODELLATO		SCALA		
29-05-2017	1:6.5	A1		
DISEGNO N°		VOLUME		
12.5/		SUPERFICIE		
Grezza		SURFACE		
Rough		Grinding		
To Rough		MASSAWEIGHT		
3.2/		FOGLIO 1 DI 1		
Finito		IL PRESENTE DISEGNO E' DI ESCLUSIVA PROPRIETA' DELLA F.M.B. E PERTANTO NE E' VIETATA LA RIPRODUZIONE ANCHE PARZIALE SENZA LA SUA AUTORIZZAZIONE SCRITTA.		
Finish				
0.8/				
Rettificato				
Grinding				
0.5+3				
3-6				
6-30				
30-120				
120-400				
400-1000				
1000-2000				
±0.05				
±0.05				
±0.1				
±0.15				
±0.2				
±0.3				
±0.5				