

LAYOUT PLUTON AIR

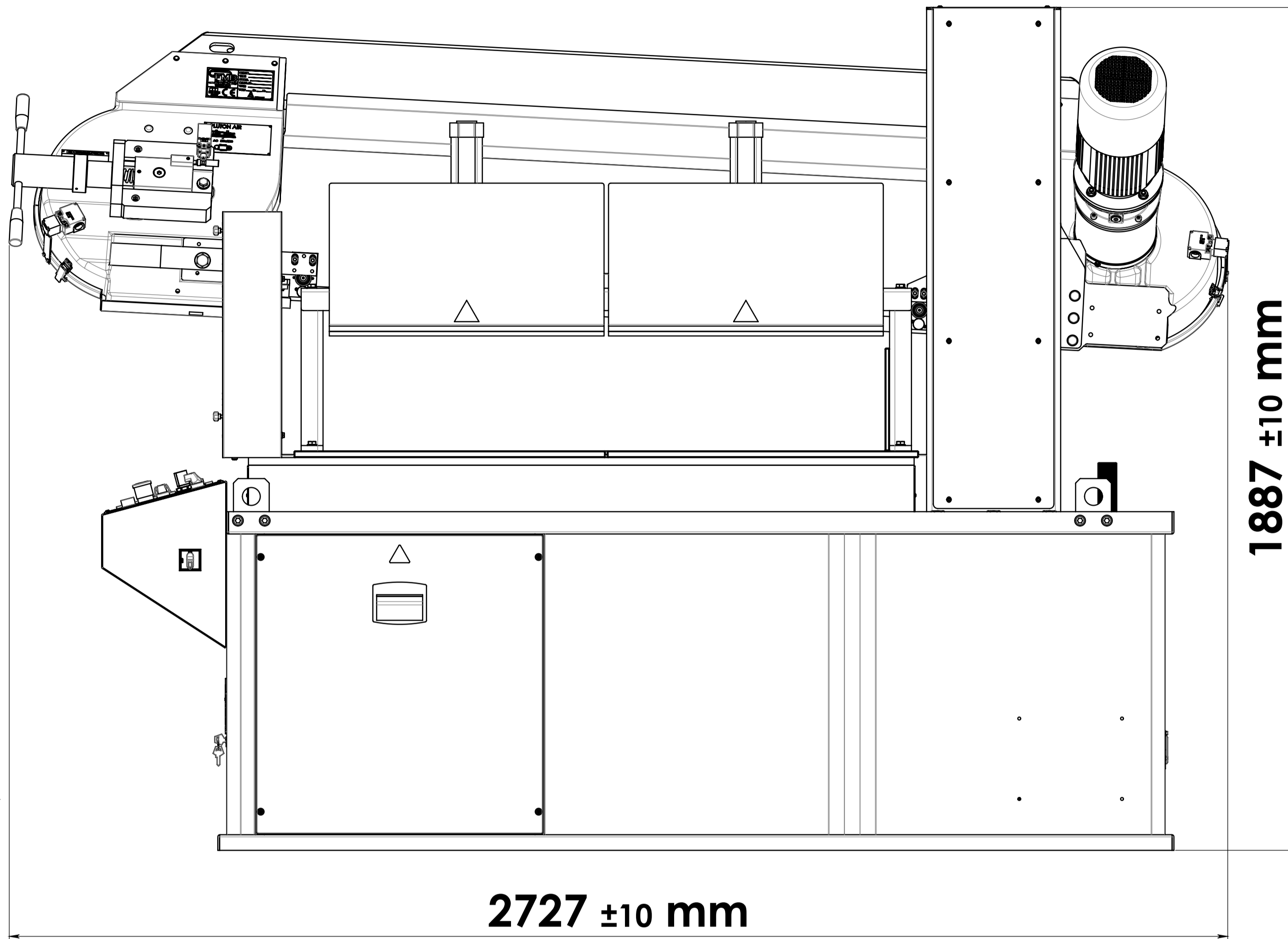

890 ± 10 mm
H PIANO DI TAGLIO
WORKTOP HEIGHT

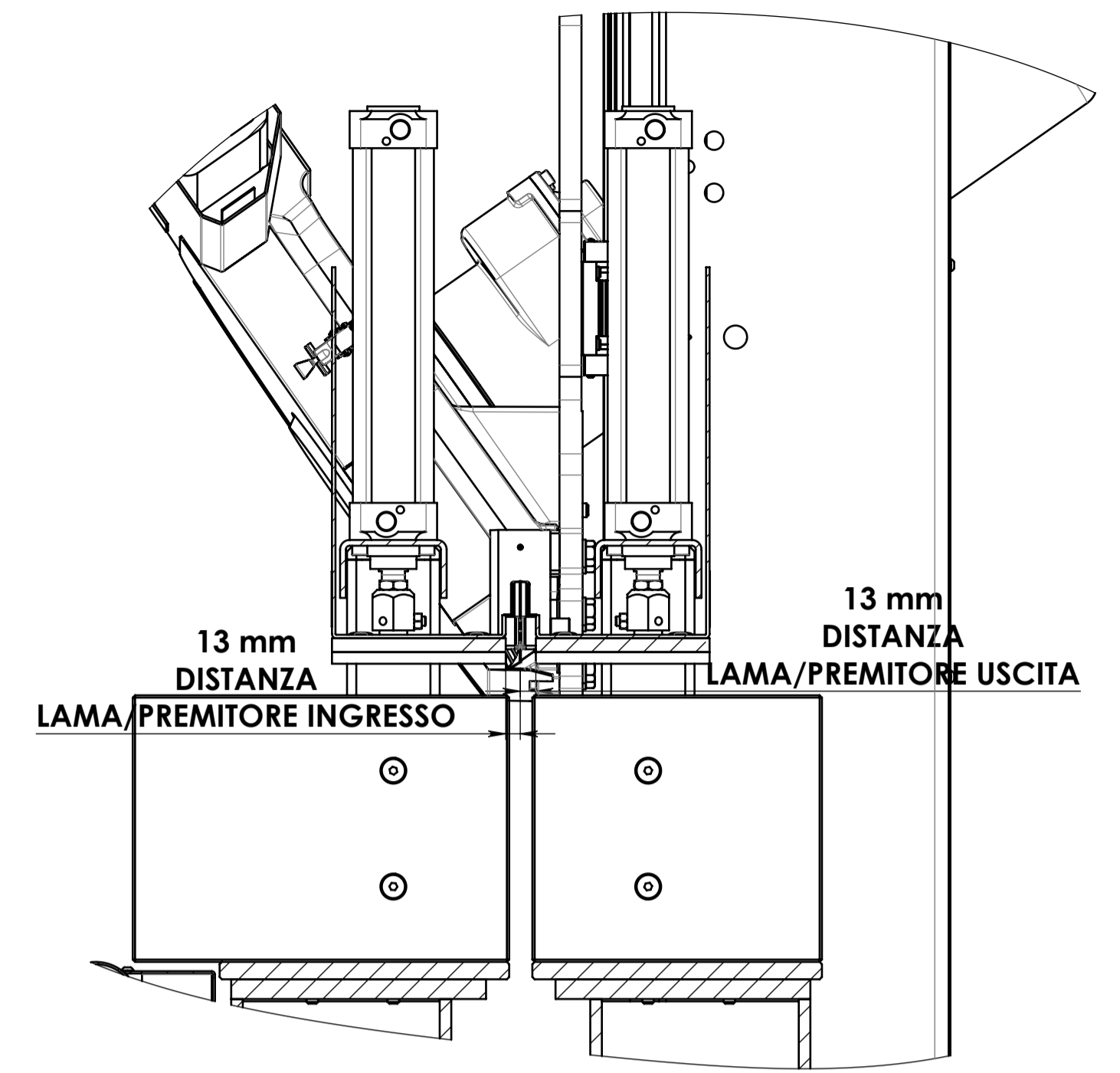
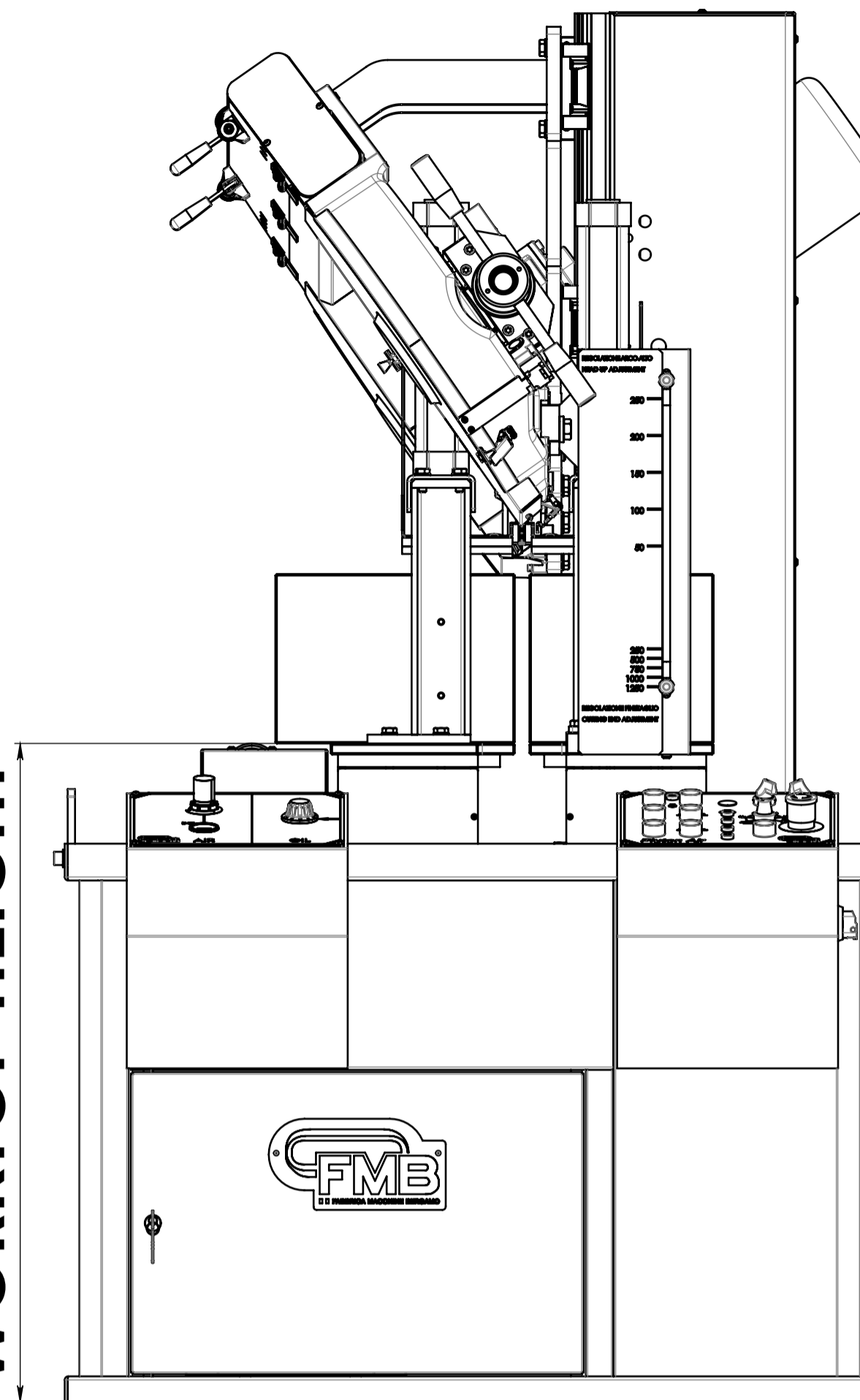

SEZIONE A-A
SCALA 1:5

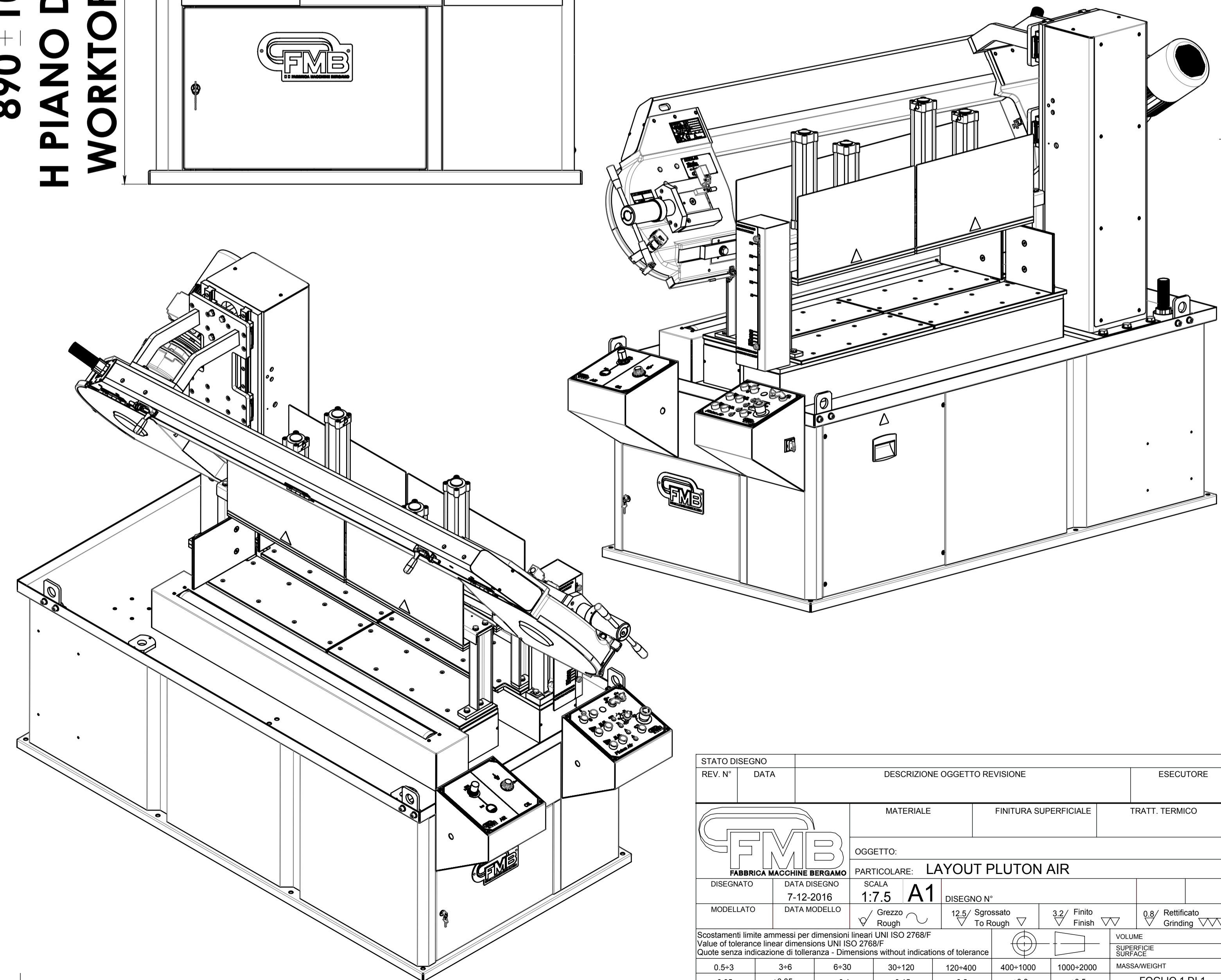
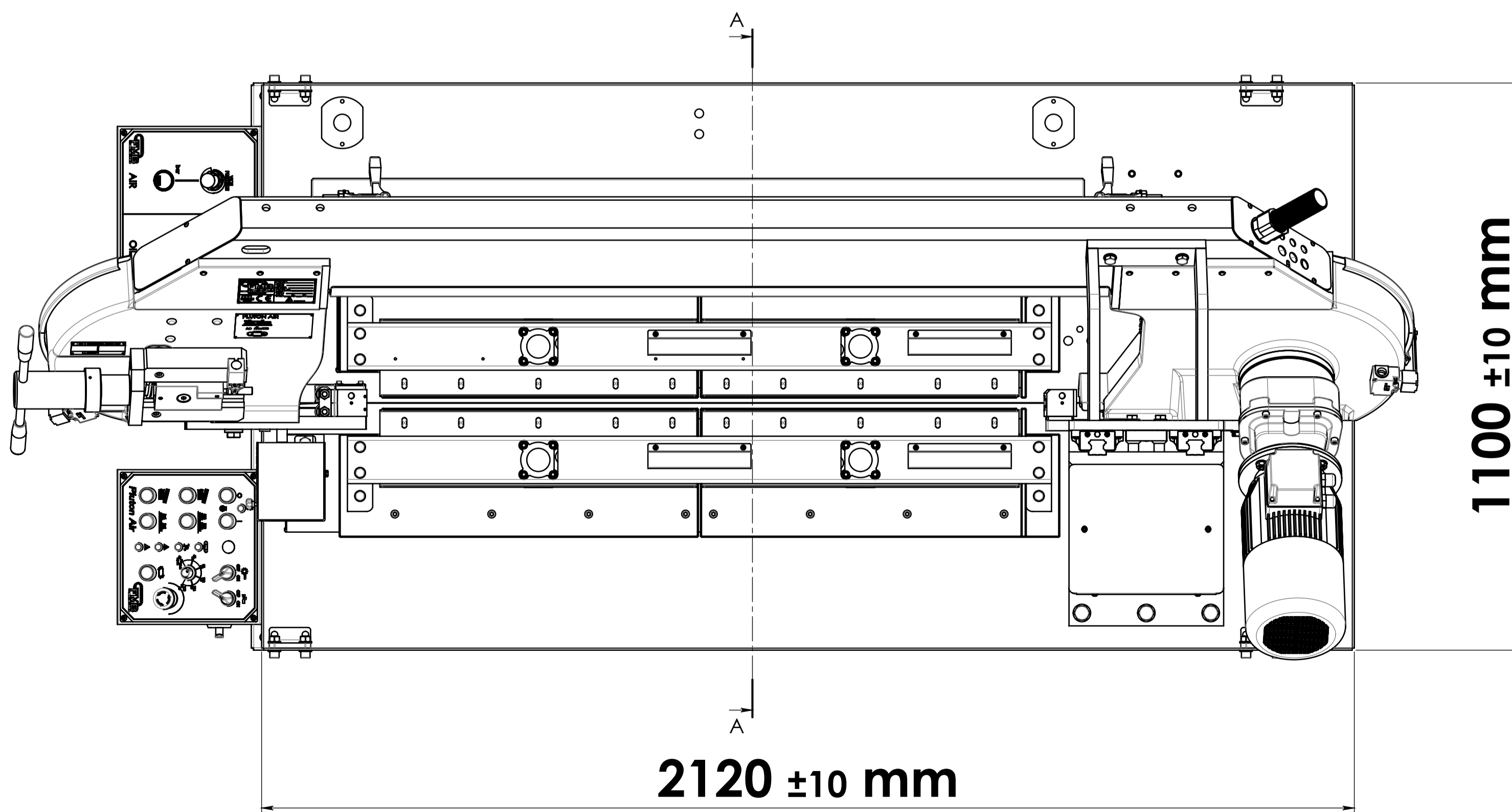

STATO DISEGNO		DESCRIZIONE OGGETTO REVISIONE		ESECUTORE
REV. N°	DATA			
		MATERIALE	FINITURA SUPERFICIALE	TRATT. TERMICO
		OGGETTO: LAYOUT PLUTON AIR		
DISEGNATO	DATA DISEGNO	PARTICOLARE: LAYOUT PLUTON AIR		
7-12-2016	7-12-2016	SCALA: 1:7.5 A1		
MODELLATO	DATA MODELLO	<input checked="" type="checkbox"/> Grezzo <input type="checkbox"/> Finito	<input type="checkbox"/> Sgrossato <input type="checkbox"/> To Rough	<input type="checkbox"/> 3/2 Finito <input type="checkbox"/> Finish
<small>Scostamenti limite ammessi per dimensioni lineari UNI ISO 2768/F</small> <small>Value of tolerance linear dimensions UNI ISO 2768/F</small> <small>Quote senza indicazione di tolleranza - Dimensions without indications of tolerance</small>		<input type="checkbox"/> 0.5+3 <input type="checkbox"/> ±0.05	<input type="checkbox"/> 3-6 <input type="checkbox"/> ±0.05	<input type="checkbox"/> 6-30 <input type="checkbox"/> ±0.1
		<input type="checkbox"/> 30-120 <input type="checkbox"/> ±0.15	<input type="checkbox"/> 120-400 <input type="checkbox"/> ±0.2	<input type="checkbox"/> 400-1000 <input type="checkbox"/> ±0.3
		<input type="checkbox"/> 1000-2000 <input type="checkbox"/> ±0.5	<input type="checkbox"/> VOLUME SUPERFICIE SURFACE <input type="checkbox"/> MASSA/WEIGHT	
FOGLIO 1 DI 1				
<small>IL PRESENTE DISEGNO E' DI ESCLUSIVA PROPRIETA' DELLA F.M.B. E PERTANTO NE E' VIETATA LA RIPRODUZIONE ANCHE PARZIALE SENZA LA SUA AUTORIZZAZIONE SCRITTA.</small>				