

TRUMPF STYLE



Press brake tooling and equipment

UTENSILI E ATTREZZATURE PER PRESSE PIEGATRICI

Eurostamp Tooling significa qualità, competenza e precisione. **Dal 1970 produciamo utensili e attrezzature per la piegatura straordinariamente precisi**, offrendo soluzioni di estrema qualità per tutti quei clienti che richiedono costantemente massimi livelli di performance e affidabilità.
“Eurostamp Tooling, the italian excellence”.

*Eurostamp Tooling means quality, competence, accuracy.
Since 1970 we have been manufacturing outstandingly accurate tooling and providing top quality solutions to all those customers who require the highest levels of performance and reliability.*

“Eurostamp Tooling, the italian excellence”



EUROSTAMP TOOLING
the Italian excellence



EUROSTAMP TOOLING

the Italian excellence

L'azienda è stata creata nel 1970 e, sin da allora, siamo orgogliosi di produrre e commercializzare **utensili e attrezzature per la piegatura** altamente performanti, affidabili e caratterizzati dai più elevati standard di qualità. Il nostro parco macchine utensili a elevata tecnologia e il magazzino con ampia disponibilità ci permettono di soddisfare ogni esigenza e richiesta speciale.

I nostri utensili sono realizzati con **acciai al carbonio e acciai speciali di provenienza italiana**, con tempra a induzione sulle parti usurabili che ne garantisce una **durezza di 55-60 HRC**. Offriamo un'ampia gamma di accessori per presse piegatrici: adattatori inferiori e superiori, sistemi di bloccaggio manuali e pneumatici.

Il nostro ufficio tecnico interno, inoltre, è in grado di studiare i progetti di piegatura personalizzati in modo tempestivo e accurato.

CHI SIAMO

*The company was formed in 1970 and, since then, we have been proud to produce and market high performing, **reliable tools for bending**, which are characterised by the highest quality standards. Our highly-technological machine tool range and large warehouse facilities, allow us to meet every need and special requirement you may have*

*Our tools are made of **medium carbon steel and special Italian-sourced alloy steel**, with induction hardening on the parts subject to wear that guarantees **55-60 HRC hardness**.*

We provide a large range of accessories for press brakes: lower and upper adaptors, manual and pneumatic clamping systems. Our in-house technical office is also able to study fully customised bending projects in a timely and accurate manner.

WHO WE ARE

LA NOSTRA FILOSOFIA

Eurostamp Tooling è un'azienda con cuore italiano e anima internazionale; abbiamo deciso di concentrarci e **specializzarci esclusivamente nella produzione e sviluppo degli utensili di piegatura**, settore in cui abbiamo sviluppato la **più alta tecnologia applicata a ciascuno dei processi interni**.

Il nostro reparto produttivo pone la massima attenzione alla **cura dei dettagli, alla precisione e all'accurato** controllo della qualità con una ispirazione artigianale: selezioniamo i migliori fornitori italiani di materia prima, e investiamo costantemente **in attrezzature di qualità** e in spazi di stoccaggio di ampio respiro.

Poniamo una fortissima attenzione alla formazione dello staff tecnico e produttivo ed investiamo costantemente in **ricerca e sviluppo perché crediamo fortemente che il modo migliore per soddisfare i nostri clienti sia il superamento delle loro aspettative con soluzioni innovative e un supporto pre e post vendita di elevato livello**. Il team commerciale lavora quotidianamente a fianco dello staff tecnico e produttivo per diffondere ovunque la nostra filosofia di marchio.

OUR PHILOSOPHY

*Eurostamp Tooling is an Italian company with an international soul, we decided to **focus only on manufacturing and engineering of tooling for press brakes**, so we invested all of **our resources on the state-of-art technologies applied to any of internal processes**.*

*Our production department put the highest care on every detail, on the maximum **accuracy and on the minute quality control**, according to a craftsman mood: we selected the best raw materials suppliers among the Italian market, beside we have been steadily investing on the **highest quality equipment** and in a precisely organised warehouse.*

*We put a strong attention to train our production and engineering staff and to invest on **research and development activities** because we believe that the best way to satisfy the customer demands is to overcome his expectations with innovative solutions and with a high level pre and post sales support.*

Our sales staff works daily beside the production and the engineering departments in order to spread worldwide our brand philosophy.



*Our staff are specialists who **follow every production phase from choosing** the best steel to the procedures for machining, hardening and grinding of each piece. We are using only 100% Italian quality steel for granting always **the best accuracy and the conformity with the highest standards specifications**.*

Gli specialisti che compongono il nostro staff **controllano ogni fase produttiva**, dalla scelta delle leghe e degli acciai grezzi, **alle procedure di fresatura**, tempra e rettifica di ogni pezzo. Usiamo acciaio al 100% italiano per garantire massima **precisione e caratteristiche meccaniche ad alto standard qualitativo**.

LE COMPETENZE OUR COMPETENCES

Calcolo della forza di piega in aria

Air bending force calculation

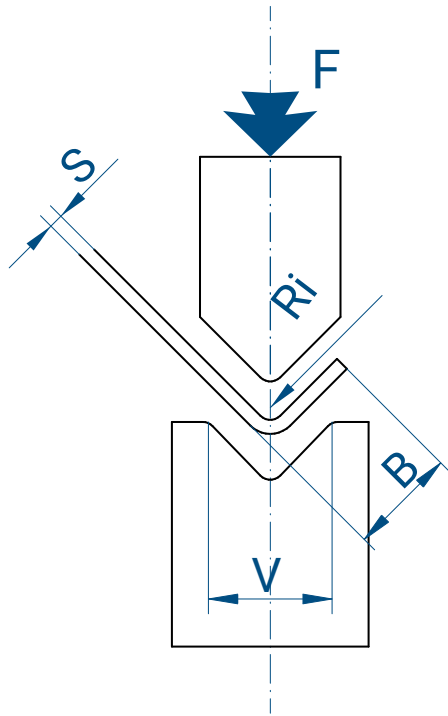

S	Spessore lamiera - mm Sheet metal thickness - mm	Ri	Raggio interno Inside radius
V	Larghezza del V V-opening	R	Alluminio 20-25 kg/mm ² Aluminium 20-25 kg/mm ²
F	Forza in T/m Force in T/m	R	Acciaio dolce 40-45 kg/mm ² Mild steel 40-45 kg/mm ²
B	Bordo minimo Shortest edge	R	Inox 65-70 kg/mm ² Stainless steel 65-70 kg/mm ²

$$F = \left| \frac{S^2 \times 2 \times R}{1.4 \times V} \right| = \dots \text{ ton/m}$$

Relazione tra spessore lamiera e larghezza V

Sheet metal thickness/V-shape width ratio

S	Spessore lamiera - mm Sheet metal thickness - mm	0,5-2,5	3-8	9-10	12 o più 12 or more
V	Larghezza del V "V" width	6 S	8 S	10 S	12 S



Tabella di piegatura in aria - Acciaio dolce / Air bending table - Mild Steel

S			mm	0,5	0,6	0,8	1	1,2	1,5	2	2,5	3	4	5	6	8	10	12	15	20	25	30	
6	4	1		3	4	7	11	16															
8	5,5	1,3			4	5	8	12	17														
10	7	1,6				4	7	10	15	27													
12	8,5	2					6	8	13	22	35												
16	11	2,6						6	9	17	26	38											
20	14	3,3							8	13	21	30	54										
25	17,5	4								11	17	24	42	67									
32	22	5									13	19	34	52	75								
40	28	6,5										15	27	42	60	107							
50	35	8											21	33	48	85	134						
63	45	10												26	38	68	105						
80	55	13													30	53	85	120					
100	71	16														43	67	96	150				
125	89	20															53	78	120	215			
160	113	26																60	95	170	265		
200	140	33																	75	135	210	300	
250	175	41																		108	170	240	
320	226	53																			85	130	190
V	B	Ri																					F

t/m

Tabella di piegatura in aria - Acciaio inox / Air bending table - Stainless Steel

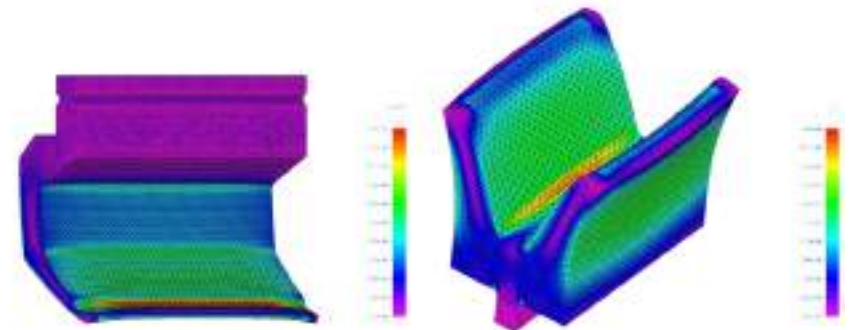
S			mm	0,5	0,6	0,8	1	1,2	1,5	2	2,5	3	4	5	6	8	10	12	15	20	25	30	
6	4	1		5	6	11	17	25															
8	5,5	1,3			6	8	12	19	26														
10	7	1,6				6	11	16	23	42													
12	8,5	2					9	12	20	34	54												
16	11	2,6						9	14	26	40	59											
20	14	3,3							12	20	33	47	84										
25	17,5	4								17	26	37	65	104									
32	22	5									20	30	53	81	117								
40	28	6,5										23	42	65	93	166							
50	35	8											33	51	75	132	208						
63	45	10												40	59	106	163						
80	55	13													47	82	132	187					
100	71	16														67	104	149	233				
125	89	20															82	121	187	334			
160	113	26																93	148	264	412		
200	140	33																	117	210	327	467	
250	175	41																		168	264	373	
320	226	53																			132	202	296
V	B	Ri																					F

t/m



EUROSTAMP TOOLING

the Italian excellence

Gli utensili superiori elencati in questa sezione possono essere installati sulle piegatrici:

Upper tooling listed on this section could be installed on the following press brakes:

Trumpf, LVD , Darley, Safan e su altre piegatrici equipaggiate con Sistema NSCL .

Trumpf, LVD, Darley, Safan and on other press brakes equipped with System NSCL (New Standard Clamping).

Questi utensili possono essere installati che su altre piegatrici tramite adattatori superiori e inferiori

These tooling are could also be installed on other press brakes by using the correct upper and lower adapters

TRUMPF

PUNZONI / PUNCHES	10	• Matrici / Dies	34 - 35
• Lunghezze standard/Standard lengths.....	10	• Matrici 1V / 1V dies H 100 86°.....	36 - 40
• Modifiche a richiesta / Modifications on request	11	• Matrici 1V / 1V dies H 100 80°.....	42
• Punzoni / Punches	12 - 13	• Matrici 1V / 1V dies H 120 80°.....	43
• Punzoni / Punches 86°.....	14 - 18	• Matrici 1V / 1V dies H 100 30°.....	44 - 47
• Punzoni / Punches 80°.....	19	• Matrici 1V / 1V dies H 100 86°.....	48 - 55
• Punzoni / Punches 60°.....	20	• Matrici 1V / 1V dies H 100 84°.....	56 - 58
• Punzoni / Punches 28°.....	22 - 24	• Matrici 1V / 1V dies H 100 80°.....	59 - 61
• Punzoni / Punches 26°.....	25	• Matrici 1V / 1V dies H 100/120 80°.....	62 - 63
• Pulsanti / Safety buttons.....	28 - 29	• Matrici 1V / 1V dies H 120 60°.....	64
		• Matrici 1V / 1V dies H 100 30°.....	66 - 71
MATRICI / DIES	31	• Matrici 1V / 1V dies H 150 86°.....	72 - 74
• Lunghezze standard/Standard lengths.....	31	• Matrici 1V / 1V dies H 150 30°.....	75 - 78
• Modifiche a richiesta / Modifications on request	33	• Piegaschiaccia / Flattening hemming tools	80 - 81

FRAZIONATURA STANDARD
STANDARD SEGMENTATION

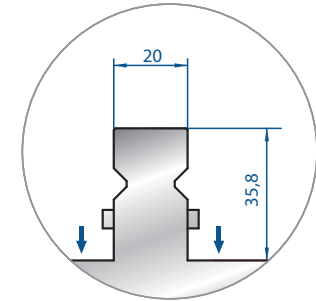
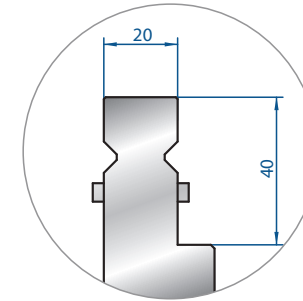
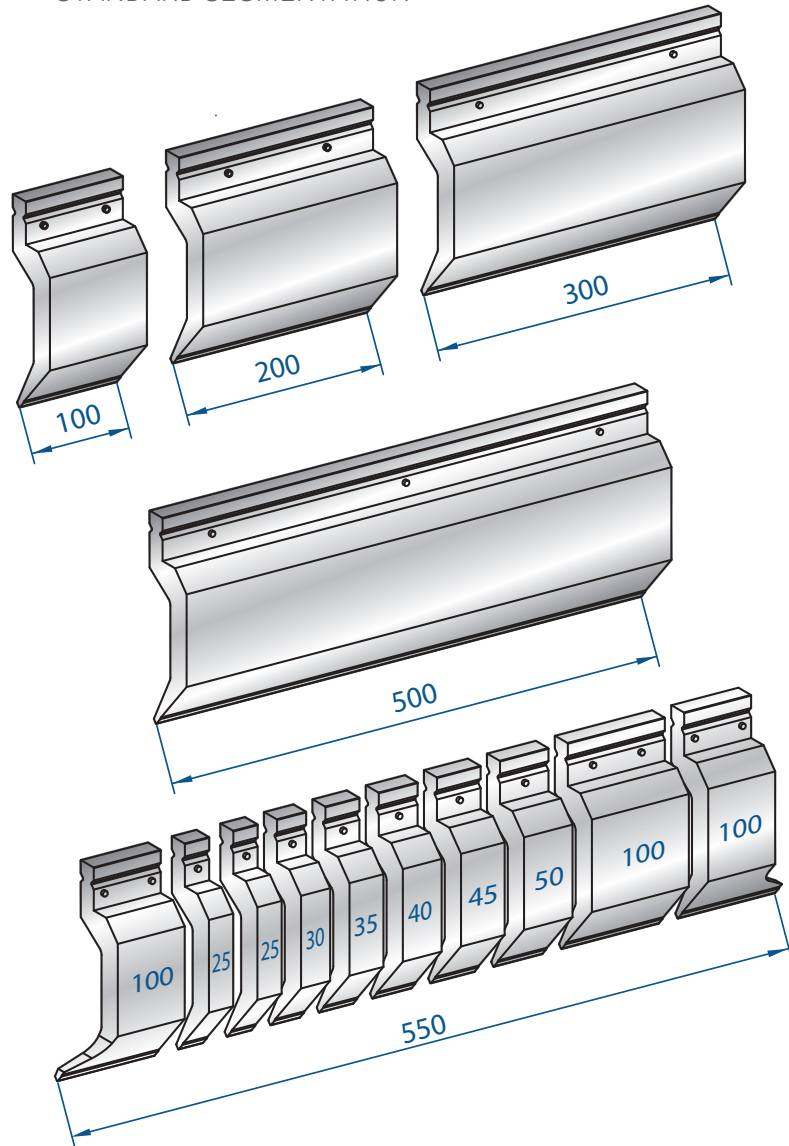

Safety button
su richiesta quando
il peso dell'utensile
è inferiore a 13,5 Kg.

Safety button
on demand when
the weight of the tool
is less than 13,5 Kg.

FRESATURA SCARPETTA
MILLED HORN

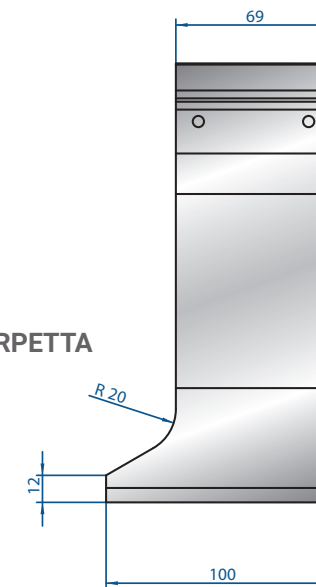

SCARPETTE SPECIALI
SPECIAL HORNS

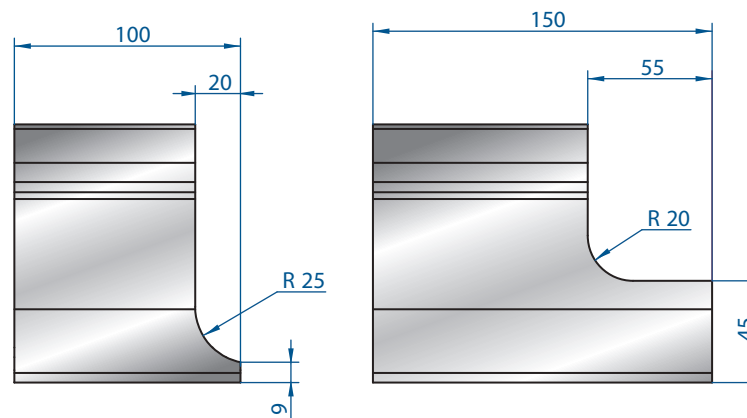

TAGLI A RICHIESTA
SPECIAL SEGMENTATION



MODIFICA RAGGIO
RADIUS MODIFICATION

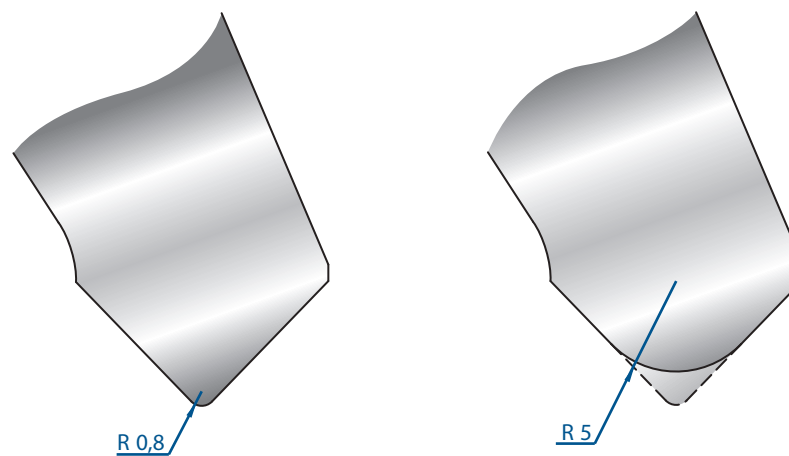

**PER PUNZONI
FOR PUNCHES
1233 - 1234 - 1235 - 1236
1237 - 1238 - 1295
1302 - 1308 - 1313 - 1314
1316 - 1317 - 1318**

550				
1050				
1250				
2050				
2550				
3050				
4050				



**PER PUNZONI
FOR PUNCHES
1294 - 1303
1319 - 1320**

**PER PUNZONE
FOR PUNCH
1315**

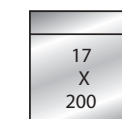
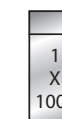
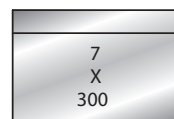
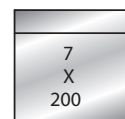
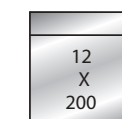
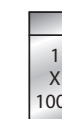
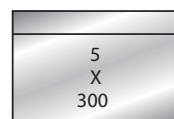
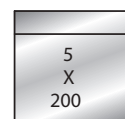
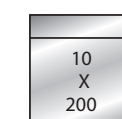
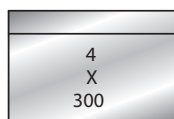
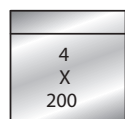
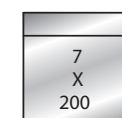
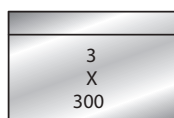
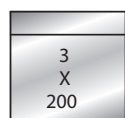
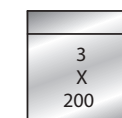
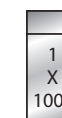
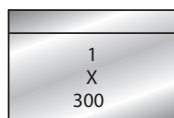
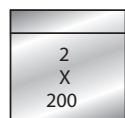
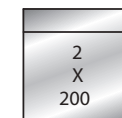
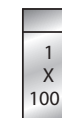
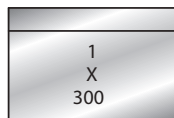
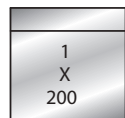

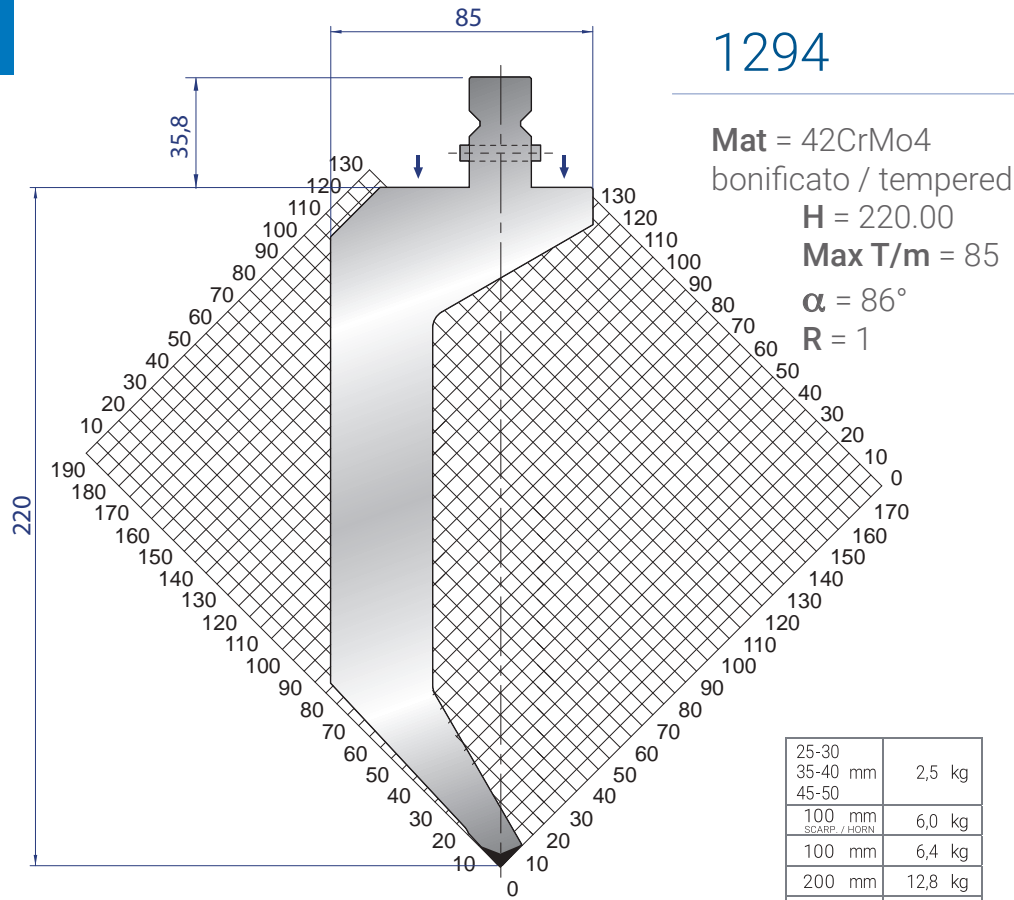

1294

Mat = 42CrMo4
bonificato / tempered
H = 220.00
Max T/m = 85
α = 86°
R = 1

25-30	
35-40 mm	2,5 kg
45-50	
100 mm	6,0 kg
100 mm	6,4 kg
200 mm	12,8 kg
300 mm	19,2 kg
500 mm	32,0 kg
550 mm	35,2 kg
1050 mm	67,2 kg
1250 mm	80,0 kg
2050 mm	131,0 kg
2550 mm	163,2 kg
3050 mm	195,2 kg
4050 mm	259,2 kg

↓
SPINTA LATERALE
SHOULDER LOAD

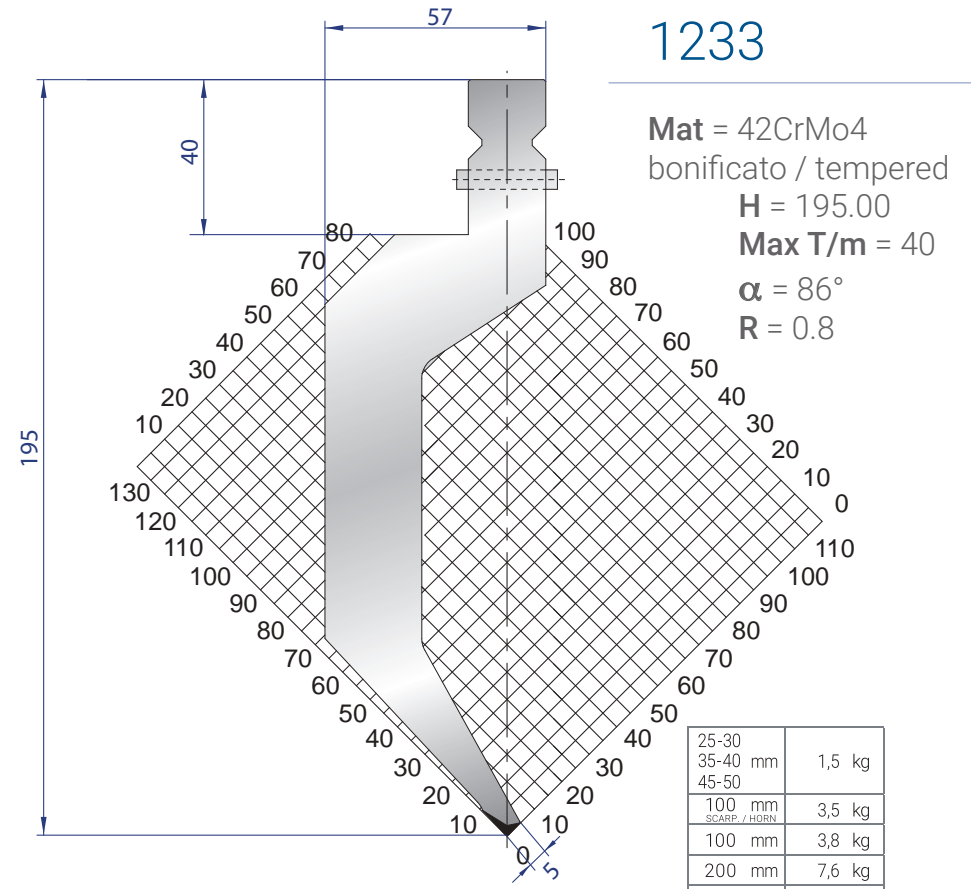

1233

Mat = 42CrMo4
bonificato / tempered
H = 195.00
Max T/m = 40
α = 86°
R = 0.8

25-30	
35-40 mm	1,5 kg
45-50	
100 mm	3,5 kg
100 mm	3,8 kg
200 mm	7,6 kg
300 mm	11,4 kg
500 mm	19,0 kg
550 mm	20,9 kg
1050 mm	39,9 kg
1250 mm	47,5 kg
2050 mm	77,9 kg
2550 mm	96,9 kg
3050 mm	115,9 kg
4050 mm	153,9 kg



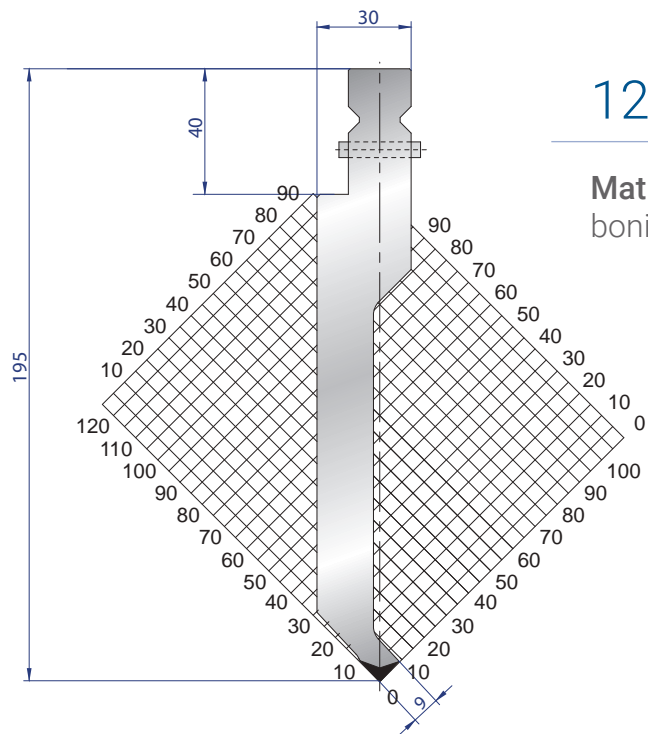

1235

Mat = 42CrMo4
bonificato / tempered
H = 195.00
Max T/m = 100
α = 86°
R = 0.8

25-30	
35-40 mm	1,2 kg
45-50	
100 mm	2,7 kg
SCARP / HORN	
100 mm	3,0 kg
200 mm	6,0 kg
300 mm	9,0 kg
500 mm	15,0 kg
550 mm	16,5 kg
FRAZ. / SECT.	
1050 mm	31,5 kg
FRAZ. B / SECT. B	
1250 mm	37,5 kg
FRAZ. B / SECT. B	
2050 mm	61,5 kg
FRAZ. B / SECT. B	
2550 mm	76,5 kg
FRAZ. B / SECT. B	
3050 mm	91,5 kg
FRAZ. B / SECT. B	
4050 mm	121,5 kg
FRAZ. B / SECT. B	

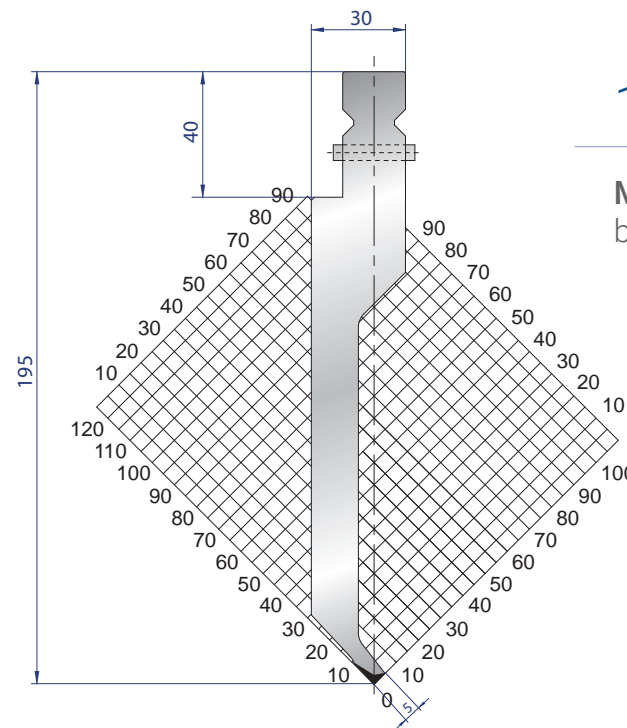

1234

Mat = 42CrMo4
bonificato / tempered
H = 195.00
Max T/m = 30
α = 86°
R = 0.6

25-30	
35-40 mm	1,1 kg
45-50	
100 mm	2,7 kg
SCARP / HORN	
100 mm	2,9 kg
200 mm	5,8 kg
300 mm	8,7 kg
500 mm	14,5 kg
550 mm	15,9 kg
FRAZ. / SECT.	
1050 mm	30,4 kg
FRAZ. B / SECT. B	
1250 mm	36,2 kg
FRAZ. B / SECT. B	
2050 mm	59,4 kg
FRAZ. B / SECT. B	
2550 mm	73,9 kg
FRAZ. B / SECT. B	
3050 mm	88,4 kg
FRAZ. B / SECT. B	
4050 mm	117,4 kg
FRAZ. B / SECT. B	

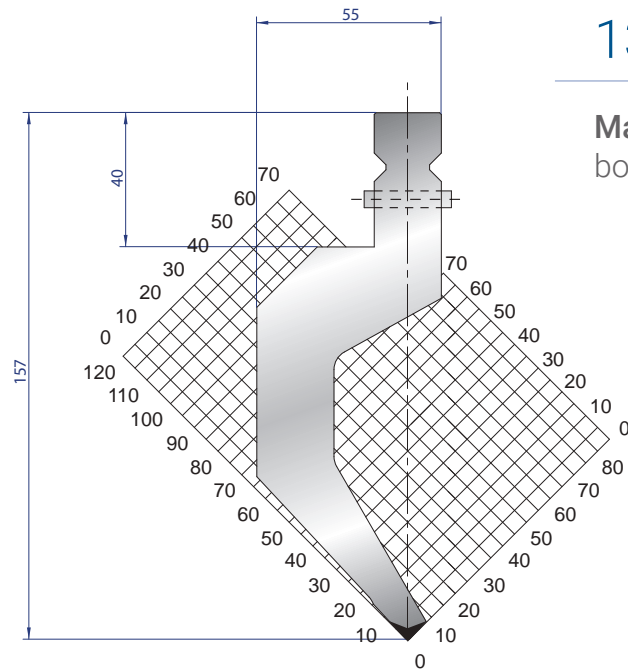

1314

Mat = 42CrMo4
bonificato / tempered
H = 157.00
Max T/m = 65
 α = 86°
R = 1

25-30	
35-40 mm	1,2 kg
45-50	
100 mm	2,5 kg
SCARP. / HORN	
100 mm	3,0 kg
200 mm	6,0 kg
300 mm	9,0 kg
500 mm	15,0 kg
550 mm	16,5 kg
FRAZ. / SECT.	
1050 mm	31,5 kg
FRAZ. B / SECT. B	
1250 mm	37,5 kg
FRAZ. B / SECT. B	
2050 mm	kg
FRAZ. B / SECT. B	
2550 mm	76,5 kg
FRAZ. B / SECT. B	
3050 mm	91,5 kg
FRAZ. B / SECT. B	
4050 mm	121,5 kg
FRAZ. B / SECT. B	



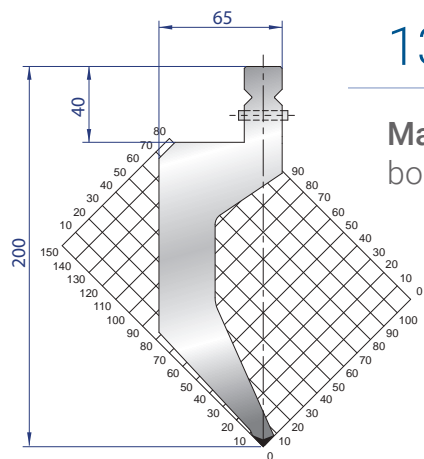

1320

Mat = 42CrMo4
bonificato / tempered
H = 200.00
Max T/m = 100
α = 86°
R = 1.5

25-30	
35-40 mm	1,2 kg
45-50	
100 mm	2,8 kg
SCARP. / HORN	
100 mm	3,1 kg
200 mm	6,2 kg
300 mm	9,3 kg
500 mm	15,4 kg
550 mm	17,0 kg
FRAZ. / SECT.	
1050 mm	32,5 kg
FRAZ. B / SECT. B	
1250 mm	38,7 kg
FRAZ. B / SECT. B	
2050 mm	63,5 kg
FRAZ. B / SECT. B	
2550 mm	79,0 kg
FRAZ. B / SECT. B	
3050 mm	94,5 kg
FRAZ. B / SECT. B	
4050 mm	125,5 kg
FRAZ. B / SECT. B	

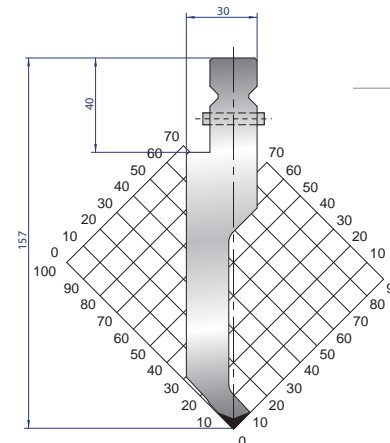

1317

Mat = 42CrMo4
bonificato / tempered
H = 157.00
Max T/m = 100
α = 86°
R = 1

25-30	
35-40 mm	0,9 kg
45-50	
100 mm	2,0 kg
SCARP. / HORN	
100 mm	2,4 kg
200 mm	4,8 kg
300 mm	7,2 kg
500 mm	12,0 kg
550 mm	13,2 kg
FRAZ. / SECT.	
1050 mm	25,2 kg
FRAZ. B / SECT. B	
1250 mm	30,0 kg
FRAZ. B / SECT. B	
2050 mm	49,2 kg
FRAZ. B / SECT. B	
2550 mm	61,2 kg
FRAZ. B / SECT. B	
3050 mm	73,2 kg
FRAZ. B / SECT. B	
4050 mm	97,2 kg
FRAZ. B / SECT. B	

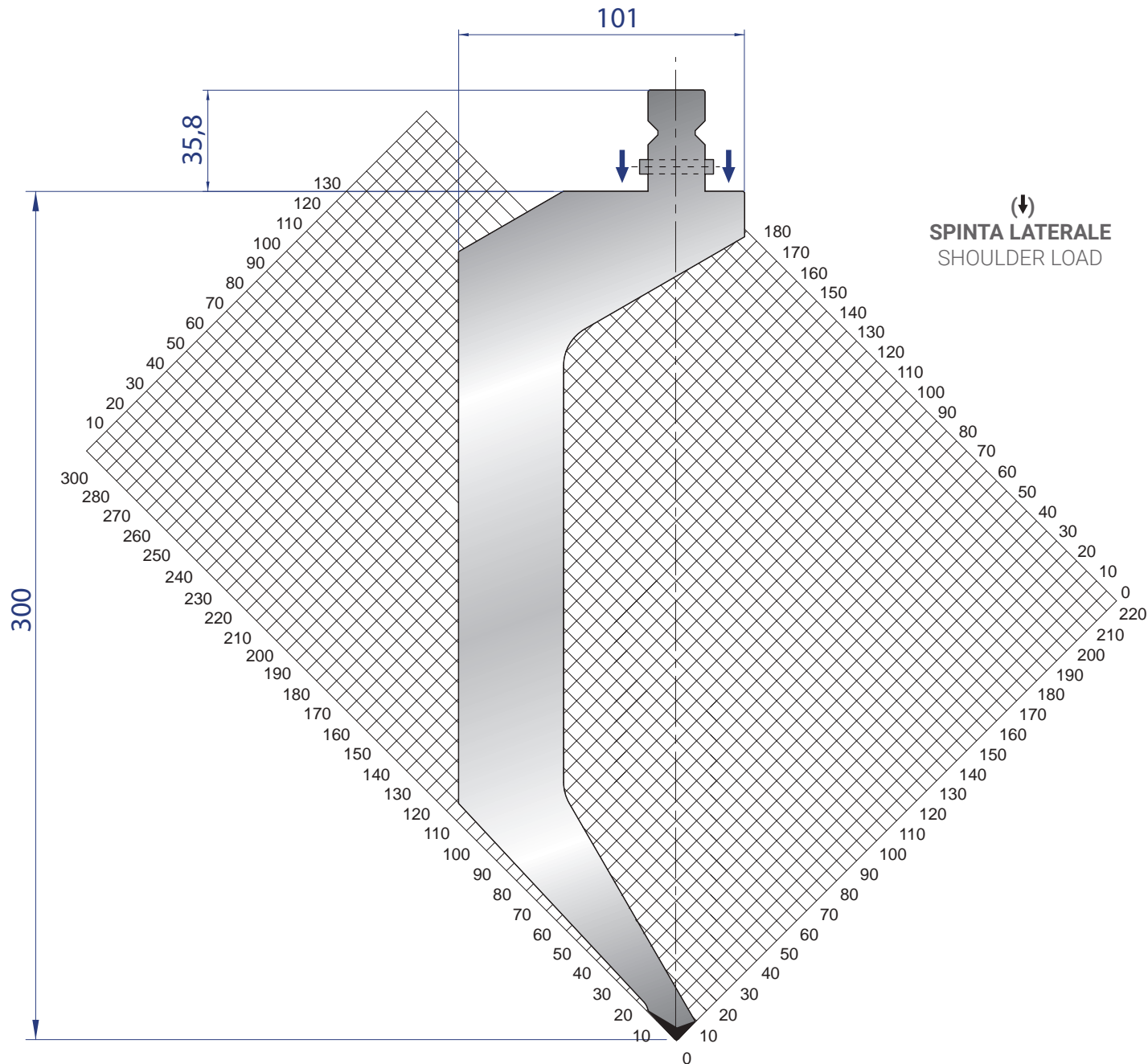

1315

Mat = 42CrMo4
bonificato / tempered
H = 300.00
Max T/m = 80
 α = 86°
R = 1

25-30	
35-40 mm	3,9 kg
45-50	
100 mm	9,0 kg
SCARP / HORN	
100 mm	9,8 kg
200 mm	19,6 kg
550 mm	49,6 kg
FRAZ. / SECT.	
1050 mm	102,9 kg
FRAZ. B / SECT. B	
1250 mm	122,5 kg
FRAZ. B / SECT. B	
2050 mm	200,9 kg
FRAZ. B / SECT. B	
2550 mm	249,9 kg
FRAZ. B / SECT. B	
3050 mm	298,9 kg
FRAZ. B / SECT. B	
4050 mm	396,9 kg
FRAZ. B / SECT. B	



PUNZONI - 80° / PUNCHES - 80°

TRUMPF
STYLE

1319

Mat = 42CrMo4
bonificato / tempered

H = 177.00

Max T/m = 20

$\alpha = 80^\circ$

R = 0.5

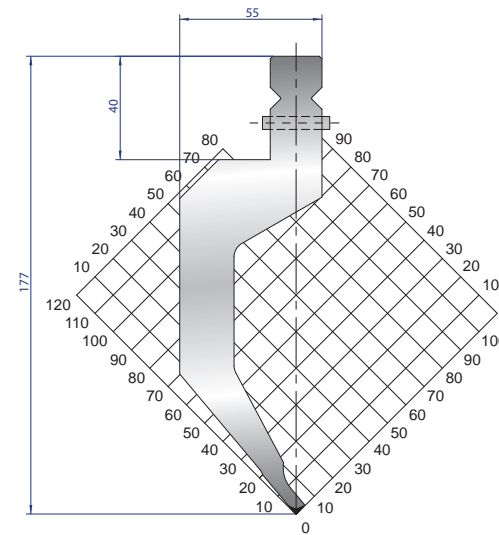

25-30	
35-40 mm	1,2 kg
45-50	
100 mm	2,9 kg
SCARP. / HORN	3,1 kg
200 mm	6,2 kg
300 mm	9,3 kg
500 mm	15,4 kg
550 mm	17,0 kg
FRAZ. / SECT.	
1050 mm	32,5 kg
FRAZ. B / SECT. B	
1250 mm	38,7 kg
FRAZ. B / SECT. B	
2050 mm	63,5 kg
FRAZ. B / SECT. B	
2550 mm	79,0 kg
FRAZ. B / SECT. B	
3050 mm	94,5 kg
FRAZ. B / SECT. B	
4050 mm	125,5 kg
FRAZ. B / SECT. B	

1303

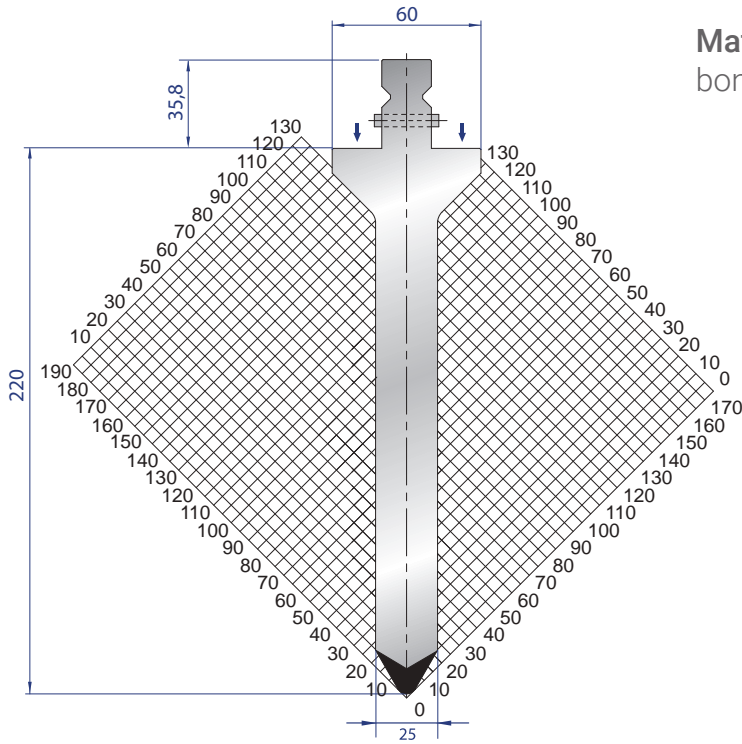

Mat = 42CrMo4
bonificato / tempered
H = 220.00
Max T/m = 100
 α = 60°
R = 4

25-30	
35-40 mm	2,0 kg
45-50	
100 mm	4,6 kg
SCARP. / HORN	
100 mm	5,2 kg
200 mm	10,4 kg
300 mm	15,6 kg
500 mm	26,0 kg
550 mm	28,6 kg
FRAZ. / SECT.	
1050 mm	54,6 kg
FRAZ. B. / SECT. B.	
1250 mm	65,0 kg
FRAZ. B. / SECT. B.	
2050 mm	106,6 kg
FRAZ. B. / SECT. B.	
2550 mm	132,6 kg
FRAZ. B. / SECT. B.	
3050 mm	158,6 kg
FRAZ. B. / SECT. B.	
4050 mm	210,6 kg
FRAZ. B. / SECT. B.	

1318

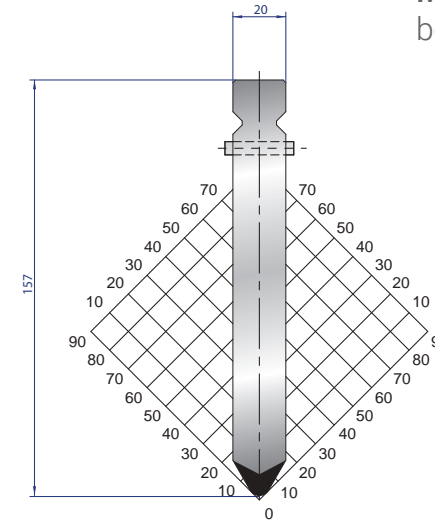

Mat = 42CrMo4
bonificato / tempered
H = 157.00
Max T/m = 100
 α = 60°
R = 4

25-30	
35-40 mm	1,0 kg
45-50	
100 mm	2,5 kg
SCARP. / HORN	
100 mm	2,7 kg
200 mm	5,4 kg
300 mm	8,1 kg
500 mm	13,5 kg
550 mm	14,9 kg
FRAZ. / SECT.	
1050 mm	28,3 kg
FRAZ. B. / SECT. B.	
1250 mm	33,7 kg
FRAZ. B. / SECT. B.	
2050 mm	55,3 kg
FRAZ. B. / SECT. B.	
2550 mm	68,8 kg
FRAZ. B. / SECT. B.	
3050 mm	82,3 kg
FRAZ. B. / SECT. B.	
4050 mm	109,3 kg
FRAZ. B. / SECT. B.	

(↓)
SPINTA LATERALE
SHOULDER LOAD



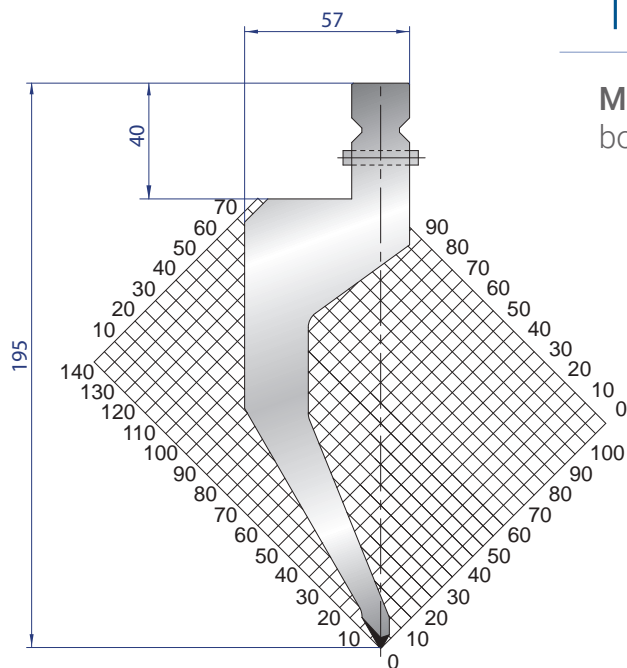

1236

Mat = 42CrMo4
bonificato / tempered

H = 195.00

Max T/m = 40

α = 60°

R = 0.8

25-30	
35-40 mm	1,4 kg
45-50	
100 mm	3,0 kg
SCARP / HORN	
100 mm	3,5 kg
200 mm	7,0 kg
300 mm	10,5 kg
500 mm	17,5 kg
550 mm	19,2 kg
FRAZ. / SECT.	
1050 mm	36,7 kg
FRAZ. B. / SECT. B.	
1250 mm	43,7 kg
FRAZ. B. / SECT. B.	
2050 mm	71,7 kg
FRAZ. B. / SECT. B.	
2550 mm	89,2 kg
FRAZ. B. / SECT. B.	
3050 mm	106,7 kg
FRAZ. B. / SECT. B.	
4050 mm	104,7 kg
FRAZ. B. / SECT. B.	

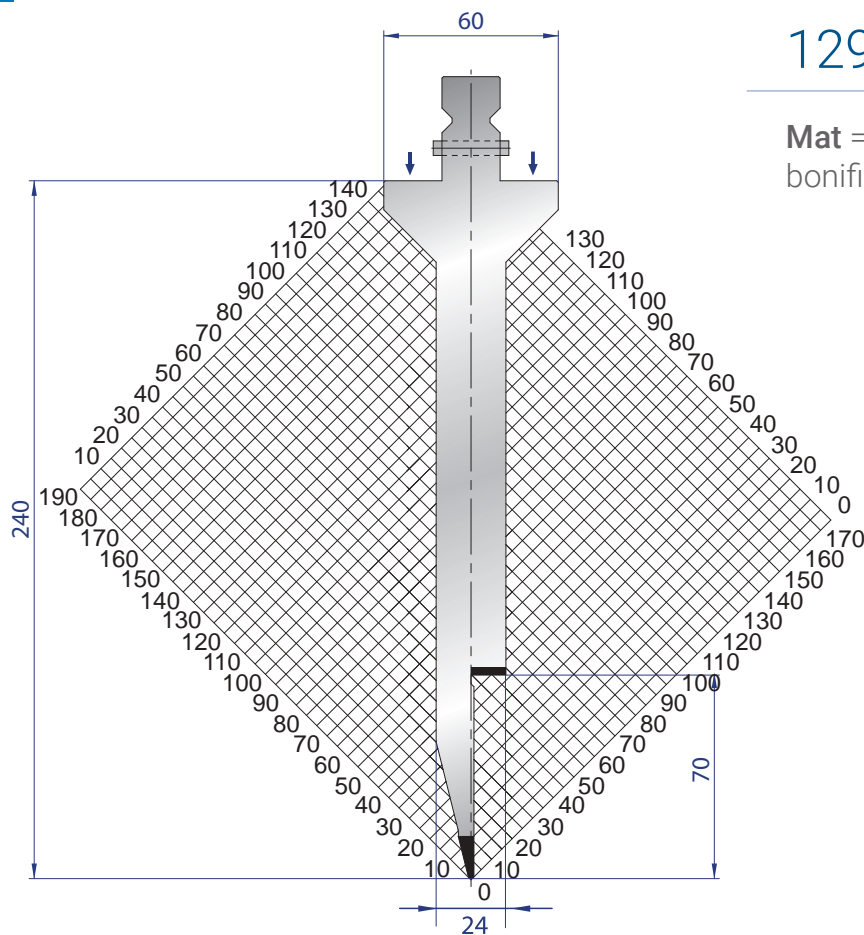

1295

Mat = 42CrMo4
bonificato / tempered
H = 240.00
Max T/m = 40
α = 28°
R = 1

25-30	
35-40 mm	1,9 kg
45-50	
100 mm	4,0 kg
100 mm	4,8 kg
200 mm	9,5 kg
300 mm	14,3 kg
500 mm	23,8 kg
550 mm	23,8 kg
1050 mm	50,4 kg
1250 mm	60,0 kg
2050 mm	98,4 kg
2550 mm	122,4 kg
3050 mm	146,4 kg
4050 mm	194,4 kg

↓
SPINTA LATERALE
SHOULDER LOAD

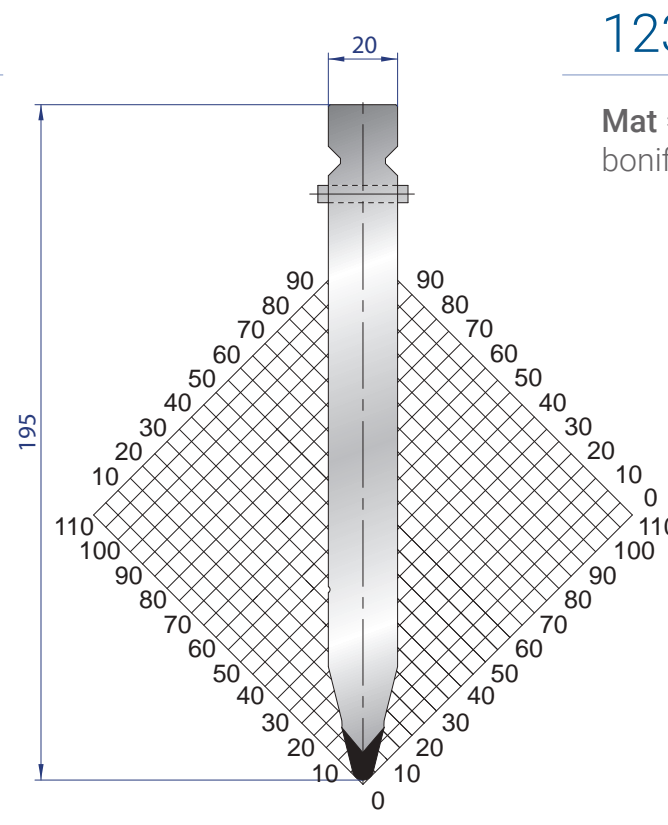

1237

Mat = 42CrMo4
bonificato / tempered
H = 195.00
Max T/m = 100
α = 28°
R = 3

25-30	
35-40 mm	1,4 kg
45-50	
100 mm	1,1 kg
100 mm	2,5 kg
200 mm	2,8 kg
300 mm	5,6 kg
500 mm	8,4 kg
550 mm	14,0 kg
1050 mm	15,4 kg
1250 mm	29,4 kg
2050 mm	35,0 kg
2550 mm	57,4 kg
3050 mm	71,4 kg
4050 mm	85,4 kg



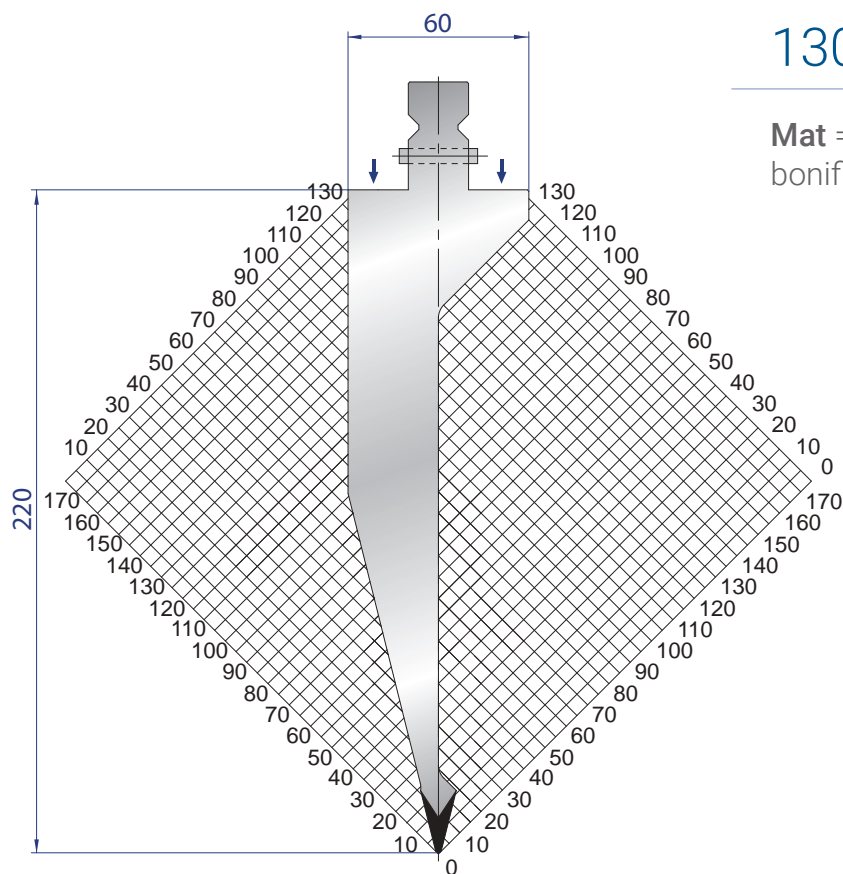

1302

Mat = 42CrMo4
 bonificato / tempered
H = 220.00
Max T/m = 80
 α = 28°
R = 1

25-30	
35-40 mm	2,0 kg
45-50	
100 mm	4,5 kg
100 mm	5,0 kg
200 mm	10,0 kg
300 mm	15,0 kg
500 mm	25,0 kg
550 mm	27,5 kg
1050 mm	52,5 kg
1250 mm	62,5 kg
2050 mm	102,5 kg
2550 mm	127,5 kg
3050 mm	152,5 kg
4050 mm	202,5 kg

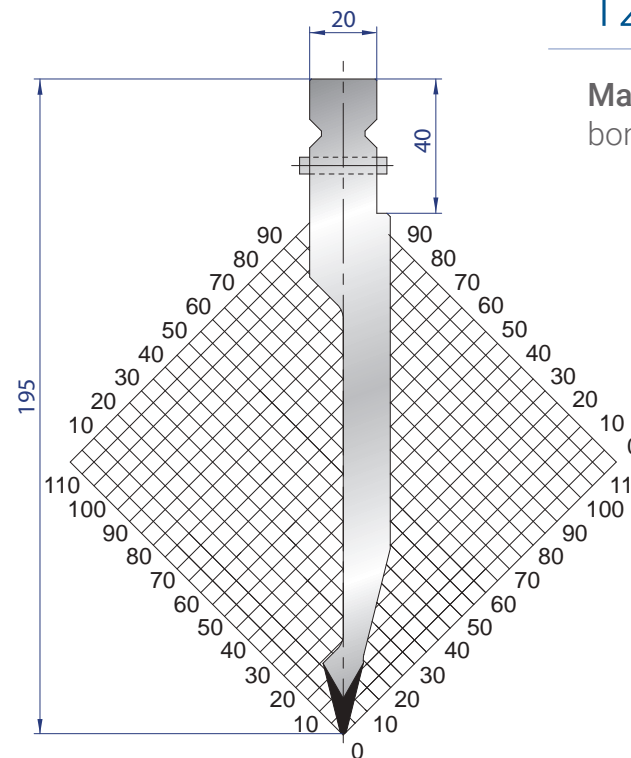

1238

Mat = 42CrMo4
 bonificato / tempered
H = 195.00
Max T/m = 80
 α = 28°
R = 1

25-30	
35-40 mm	0,9 kg
45-50	
100 mm	1,9 kg
100 mm	2,3 kg
200 mm	4,6 kg
300 mm	6,9 kg
500 mm	11,5 kg
550 mm	12,6 kg
1050 mm	24,1 kg
1250 mm	28,7 kg
2050 mm	47,1 kg
2550 mm	58,6 kg
3050 mm	70,0 kg
4050 mm	93,0 kg

↓
SPINTA LATERALE
 SHOULDER LOAD

1308

Mat = 42CrMo4
bonificato / tempered
H = 140.00
Max T/m = 40
 α = 28°
R = 1

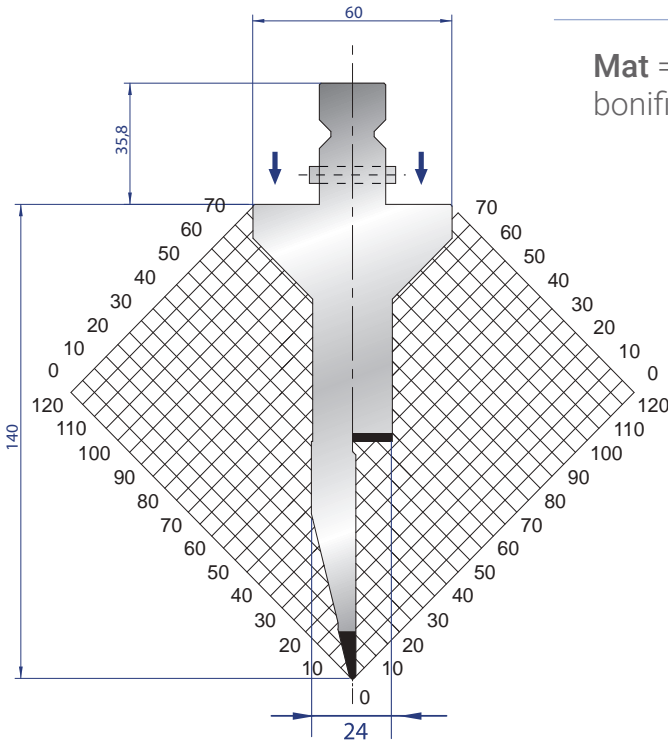

25-30		
35-40 mm		1,1 kg
45-50		
100 mm	SCARP. / HORN	2,7 kg
100 mm		2,9 kg
200 mm		5,8 kg
300 mm		8,7 kg
500 mm		14,5 kg
550 mm	FRAZ. / SECT.	15,9 kg
1050 mm	FRAZ. B / SECT. B	30,4 kg
1250 mm	FRAZ. B / SECT. B	36,2 kg
2050 mm	FRAZ. B / SECT. B	59,4 kg
2550 mm	FRAZ. B / SECT. B	73,9 kg
3050 mm	FRAZ. B / SECT. B	88,4 kg
4050 mm	FRAZ. B / SECT. B	117,4 kg

↓
SPINTA LATERALE
SHOULDER LOAD

1313

Mat = 42CrMo4
bonificato / tempered
H = 157.00
Max T/m = 80
 α = 28°
R = 1

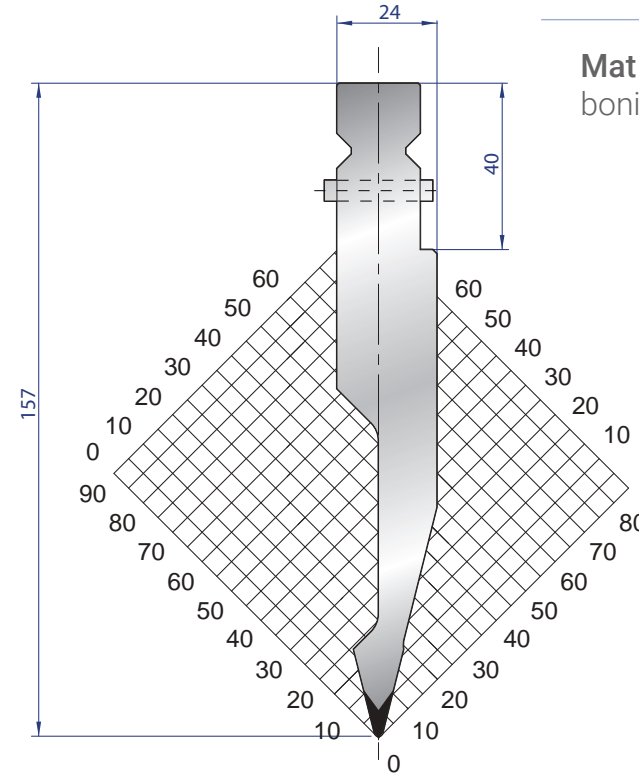

25-30		
35-40 mm		0,8 kg
45-50		
100 mm	SCARP. / HORN	1,8 kg
100 mm		2,0 kg
200 mm		4,0 kg
300 mm		6,0 kg
500 mm		10,0 kg
550 mm	FRAZ. / SECT.	11,0 kg
1050 mm	FRAZ. B / SECT. B	21,0 kg
1250 mm	FRAZ. B / SECT. B	25,0 kg
2050 mm	FRAZ. B / SECT. B	41,0 kg
2550 mm	FRAZ. B / SECT. B	51,0 kg
3050 mm	FRAZ. B / SECT. B	61,0 kg
4050 mm	FRAZ. B / SECT. B	81,0 kg



1316

Mat = 42CrMo4
 bonificato / tempered
H = 195.00
Max T/m = 100
 α = 26°
R = 0.8

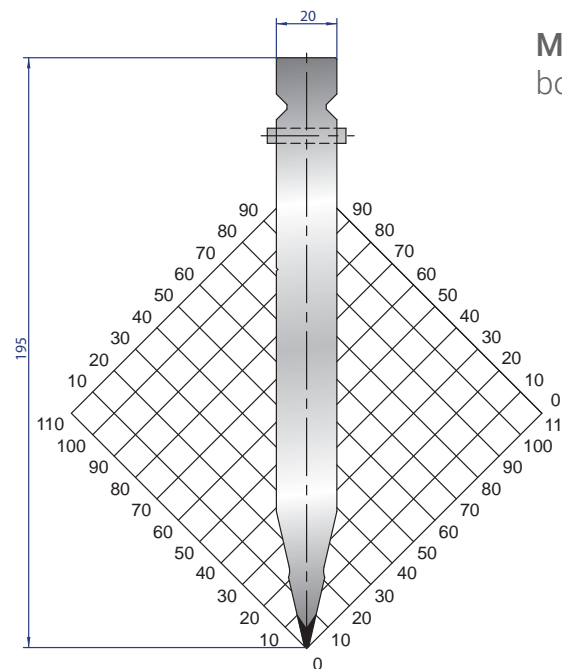

25-30	1,0 kg
35-40	
45-50	
100 mm SCARP. / HORN	2,5 kg
100 mm	2,7 kg
200 mm	5,4 kg
300 mm	8,1 kg
500 mm	13,5 kg
550 mm FRAZ. / SECT.	14,9 kg
1050 mm FRAZ. B / SECT. B	28,3 kg
1250 mm FRAZ. B / SECT. B	33,7 kg
2050 mm FRAZ. B / SECT. B	55,3 kg
2550 mm FRAZ. B / SECT. B	68,8 kg
3050 mm FRAZ. B / SECT. B	82,3 kg
4050 mm FRAZ. B / SECT. B	109,3 kg



8210

FRESATURA PULSANTE
MILLING FOR SAFETY BUTTON

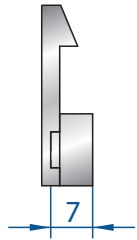

8211

CODICI / CODES
-1237 -1240
-1316 -1318

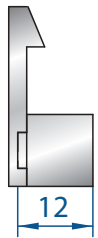

8218

CODICI / CODES
-1238 -1249
-1250 -1251- 1313

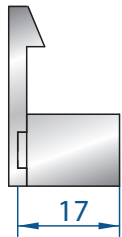

8212

CODICI / CODES
-1234 -1235
-1317 -4191

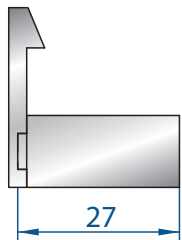

8213

CODICI / CODES
-1295-1302
-1303-1308-4361

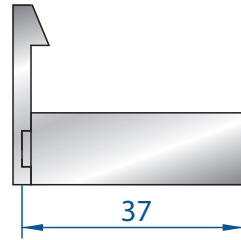

8214

CODICI / CODES
-1233 -1314
-1319

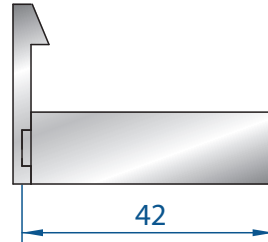

8215

CODICI / CODES
- 1236

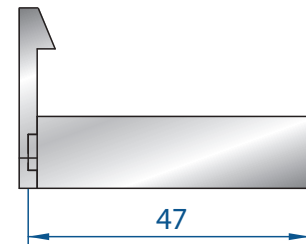

8216

CODICI / CODES
- 1294 -1320

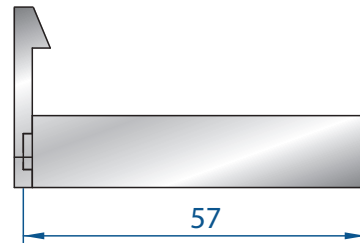

8219

CODICI / CODES
- 1315



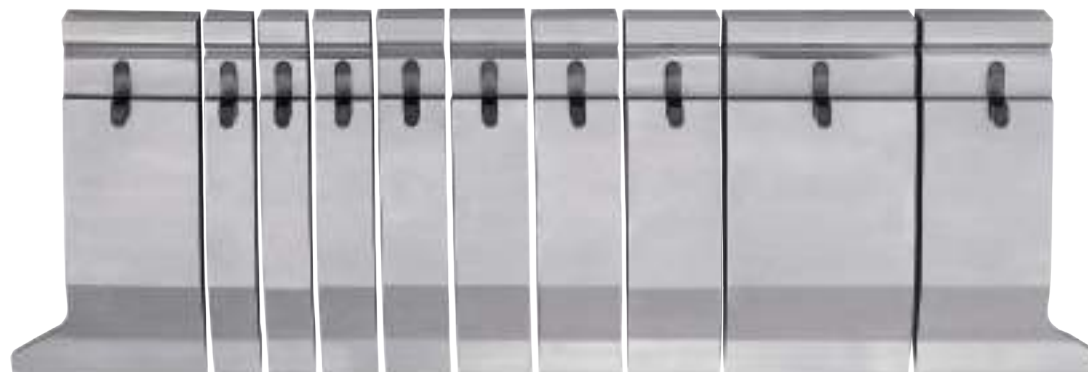
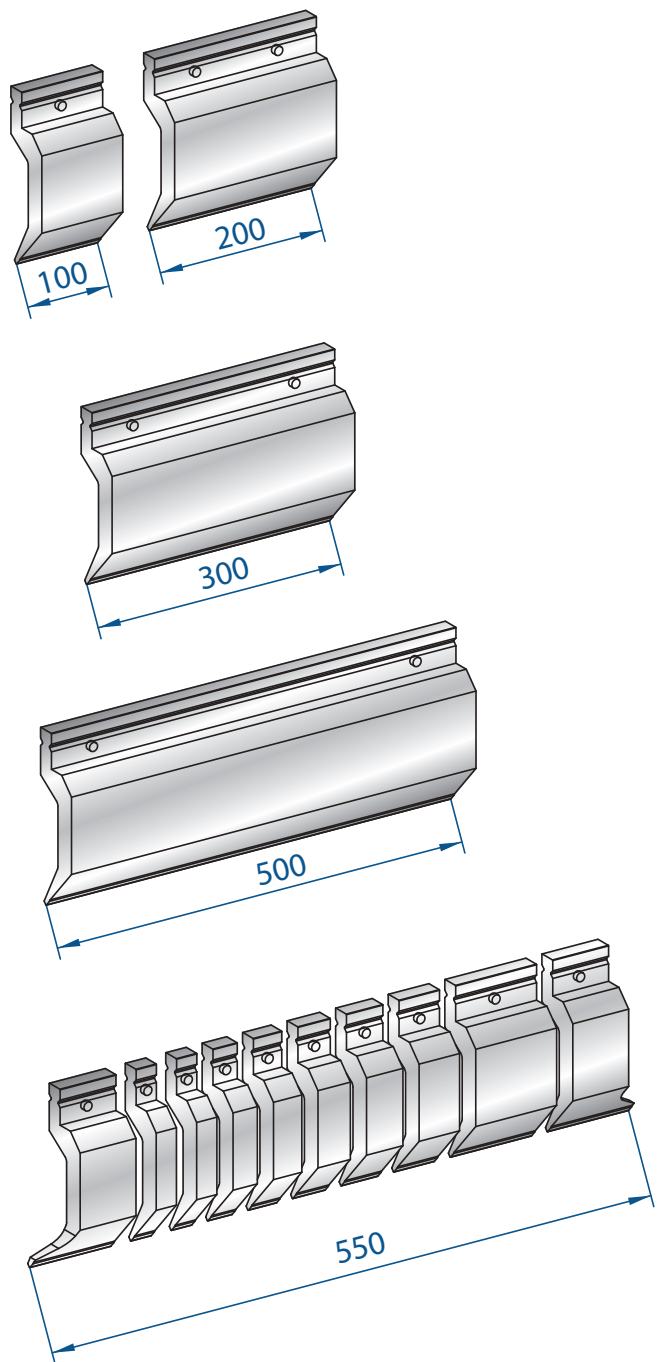



EUROSTAMP TOOLING

the Italian excellence

Gli utensili inferiori elencati in questa sezione possono essere installati sulle piegatrici:

Lower tooling listed on this section could be installed on the following press brakes:

Trumpf, Darley, Safan, Beyeler/Bystronic, SMD e su altre piegatrici equipaggiate con Sistema NSCR

Trumpf, Darley, Safan, Beyeler/Bystronic, SMD and on other press brakes equipped with System NSCR.

Questi utensili possono essere installati che su altre piegatrici tramite adattatori superiori e inferiori

These tooling are could also be installed on other press brakes by using the correct upper and lower adapters

FRAZIONATURA STANDARD
STANDARD SEGMENTATION

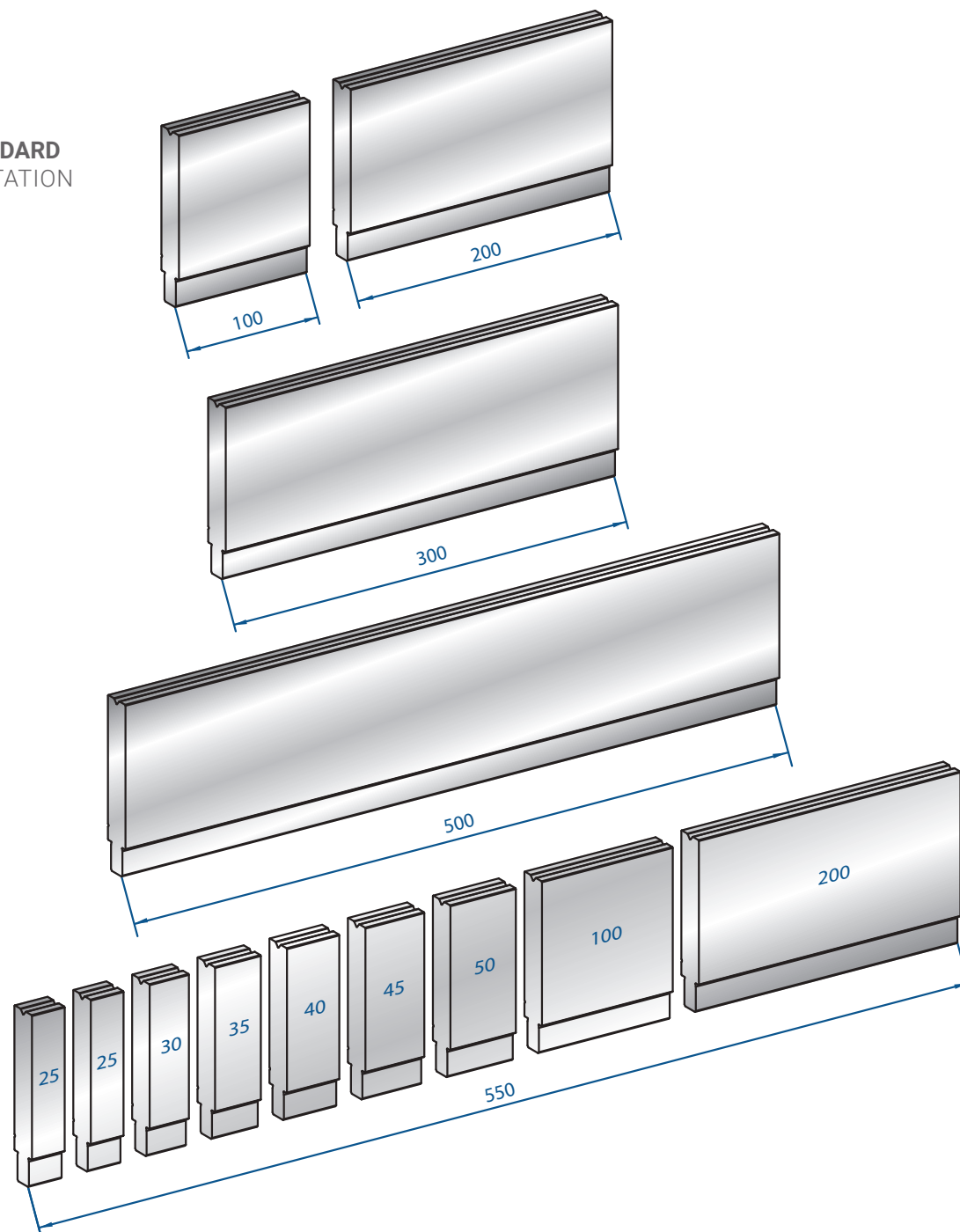

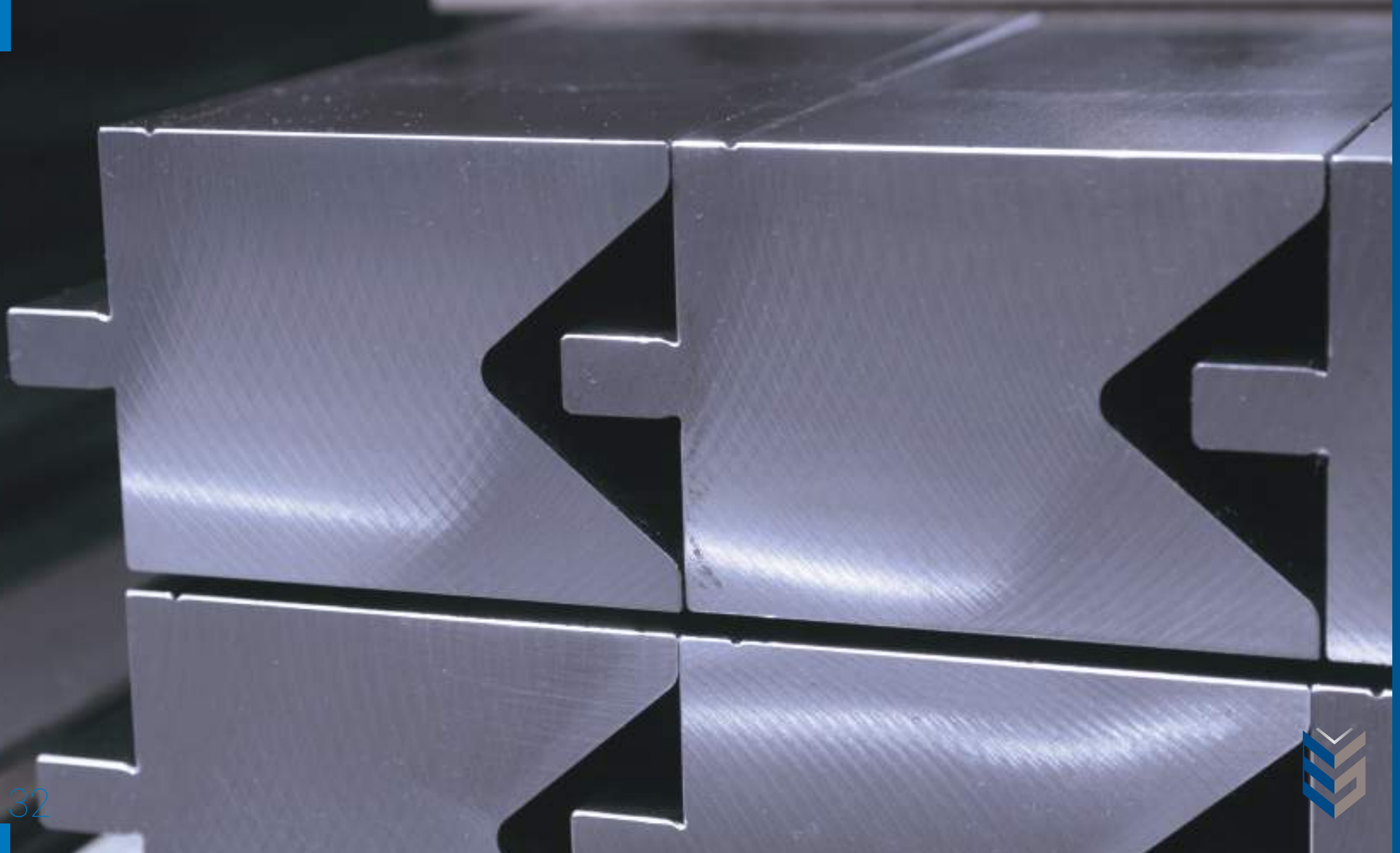

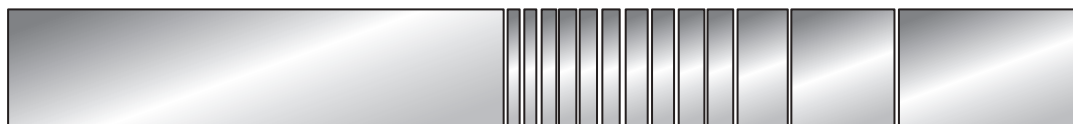

TAGLI A RICHIESTA
SPECIAL SEGMENTATION

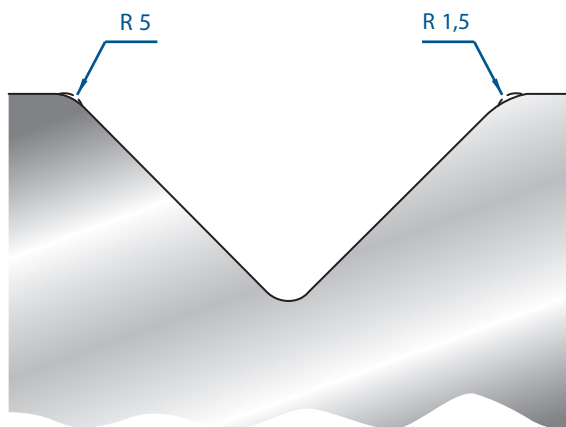

MODIFICA RAGGIO
RADIUS MODIFICATION

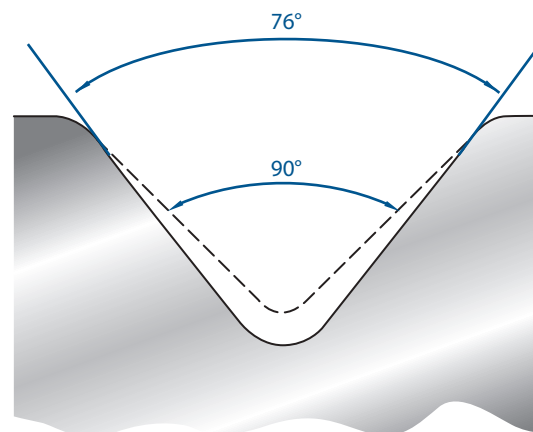

MODIFICA ANGOLO
ANGLE MODIFICATION

**PER MATRICI
FOR DIES
- 3135 - 3222
- 3223 - 3224**

**PER MATRICI
FOR DIES**

**- 3218 - 3219 - 3220
- 3221 - 3132 - 3133 - 3134**

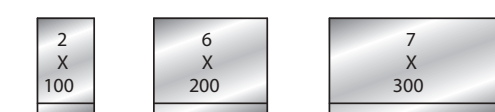
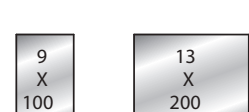
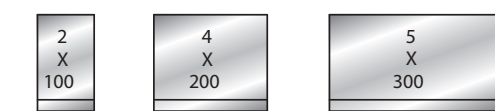
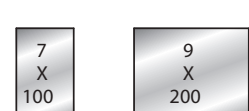
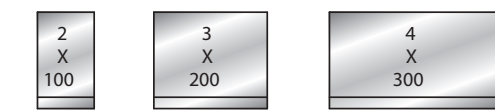
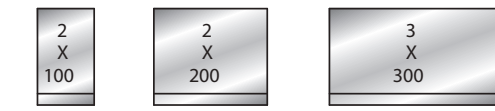
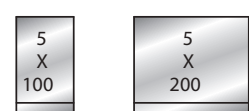
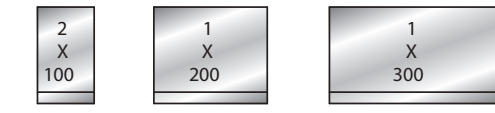
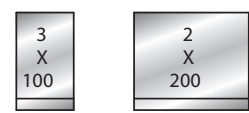
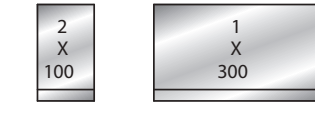
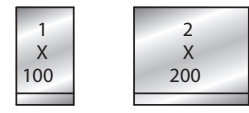

PER TUTTI GLI ALTRI TIPI DI MATRICI
FOR ALL OTHERS TYPE OF DIES

550



1050

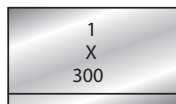

1250

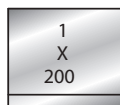

2050

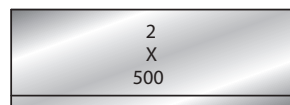
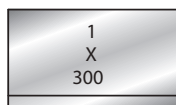

2550

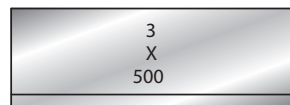
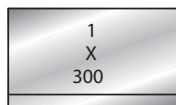

3050

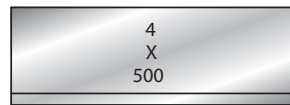
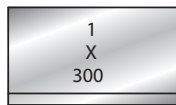

4050

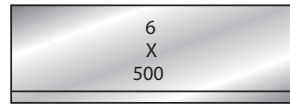

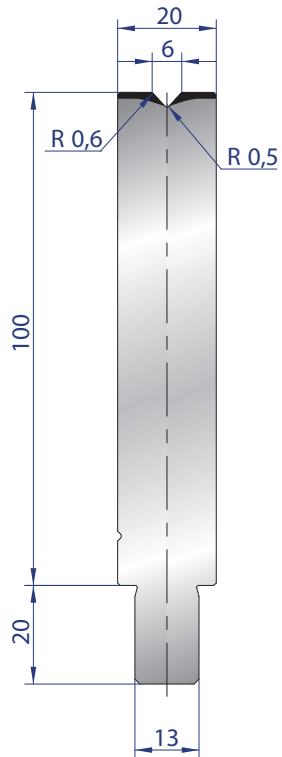

25-30	
35-40 mm	0,6 kg
45-50	
100 mm	1,8 kg
200 mm	3,6 kg
300 mm	5,4 kg
500 mm	8,7 kg
550 mm	9,6 kg
FRAZ. / SECT.	
1050 mm	18,9 kg
FRAZ. B / SECT. B	
1250 mm	22,5 kg
FRAZ. B / SECT. B	
2050 mm	36,9 kg
FRAZ. B / SECT. B	
2550 mm	45,9 kg
FRAZ. B / SECT. B	
3050 mm	54,9 kg
FRAZ. B / SECT. B	
4050 mm	72,9 kg
FRAZ. B / SECT. B	

3123

Mat = C45
Max T/m = 100
 $\alpha = 86^\circ$

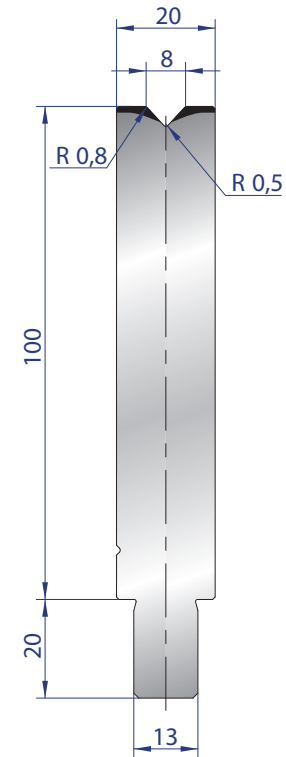

25-30	
35-40 mm	0,6 kg
45-50	
100 mm	1,8 kg
200 mm	3,6 kg
300 mm	5,4 kg
500 mm	8,7 kg
550 mm	9,6 kg
FRAZ. / SECT.	
1050 mm	18,9 kg
FRAZ. B / SECT. B	
1250 mm	22,5 kg
FRAZ. B / SECT. B	
2050 mm	36,9 kg
FRAZ. B / SECT. B	
2550 mm	45,9 kg
FRAZ. B / SECT. B	
3050 mm	54,9 kg
FRAZ. B / SECT. B	
4050 mm	72,9 kg
FRAZ. B / SECT. B	

3124

Mat = C45
Max T/m = 100
 $\alpha = 86^\circ$



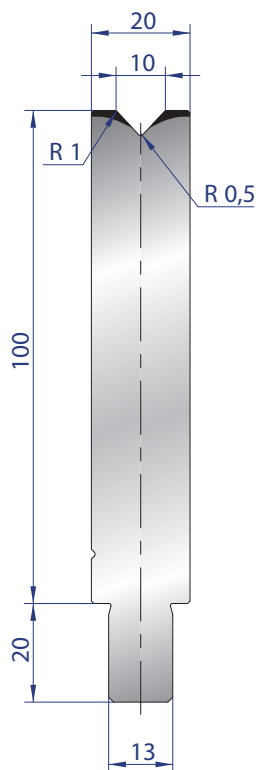

25-30	
35-40 mm	0,6 kg
45-50	
100 mm	1,8 kg
200 mm	3,6 kg
300 mm	5,4 kg
500 mm	8,7 kg
550 mm	9,6 kg
FRAZ. B / SECT. B	
1050 mm	18,9 kg
FRAZ. B / SECT. B	
1250 mm	22,5 kg
FRAZ. B / SECT. B	
2050 mm	36,9 kg
FRAZ. B / SECT. B	
2550 mm	45,9 kg
FRAZ. B / SECT. B	
3050 mm	54,9 kg
FRAZ. B / SECT. B	
4050 mm	72,9 kg
FRAZ. B / SECT. B	

3125

Mat = C45
Max T/m = 100
 $\alpha = 86^\circ$

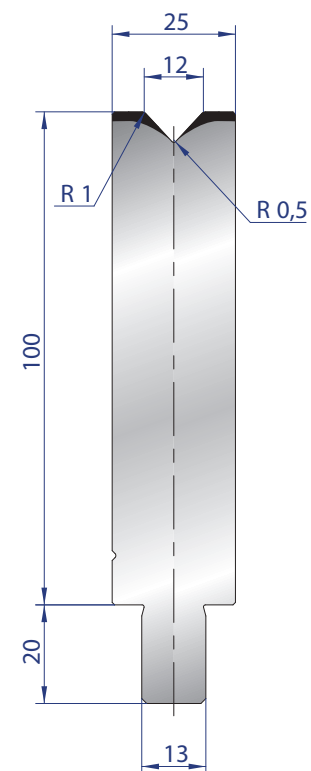

25-30	
35-40 mm	0,8 kg
45-50	
100 mm	2,0 kg
200 mm	4,1 kg
300 mm	6,2 kg
500 mm	10,2 kg
550 mm	11,3 kg
FRAZ. B / SECT. B	
1050 mm	21,0 kg
FRAZ. B / SECT. B	
1250 mm	25,0 kg
FRAZ. B / SECT. B	
2050 mm	41,0 kg
FRAZ. B / SECT. B	
2550 mm	51,0 kg
FRAZ. B / SECT. B	
3050 mm	61,0 kg
FRAZ. B / SECT. B	
4050 mm	81,0 kg
FRAZ. B / SECT. B	

3126

Mat = C45
Max T/m = 100
 $\alpha = 86^\circ$

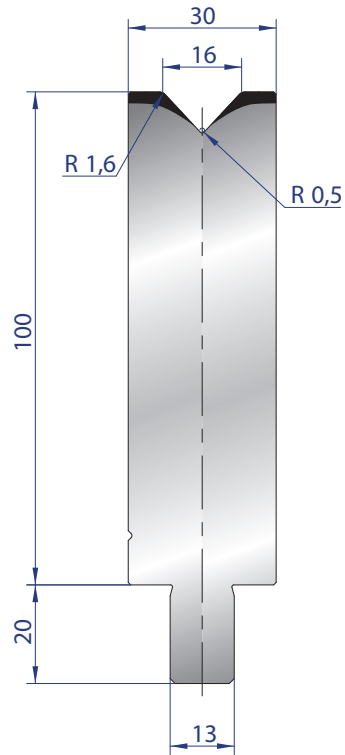

25-30	
35-40 mm	0,9 kg
45-50	
100 mm	2,4 kg
200 mm	4,8 kg
300 mm	7,2 kg
500 mm	11,8 kg
550 mm	13,0 kg
FRAZ. B / SECT. B	
1050 mm	25,2 kg
FRAZ. B / SECT. B	
1250 mm	30,0 kg
FRAZ. B / SECT. B	
2050 mm	49,2 kg
FRAZ. B / SECT. B	
2550 mm	63,7 kg
FRAZ. B / SECT. B	
3050 mm	73,2 kg
FRAZ. B / SECT. B	
4050 mm	97,2 kg
FRAZ. B / SECT. B	

3127

Mat = C45
Max T/m = 100
 $\alpha = 86^\circ$

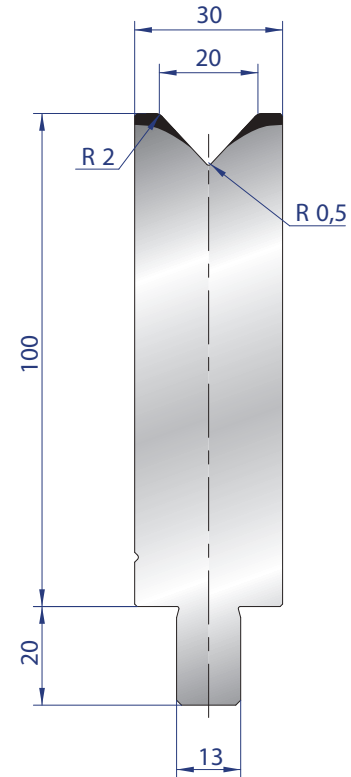

25-30	
35-40 mm	0,9 kg
45-50	
100 mm	2,4 kg
200 mm	4,8 kg
300 mm	7,2 kg
500 mm	11,8 kg
550 mm	13,0 kg
FRAZ. B / SECT. B	
1050 mm	25,2 kg
FRAZ. B / SECT. B	
1250 mm	30,0 kg
FRAZ. B / SECT. B	
2050 mm	49,2 kg
FRAZ. B / SECT. B	
2550 mm	63,7 kg
FRAZ. B / SECT. B	
3050 mm	73,2 kg
FRAZ. B / SECT. B	
4050 mm	97,2 kg
FRAZ. B / SECT. B	

3128

Mat = C45
Max T/m = 100
 $\alpha = 86^\circ$



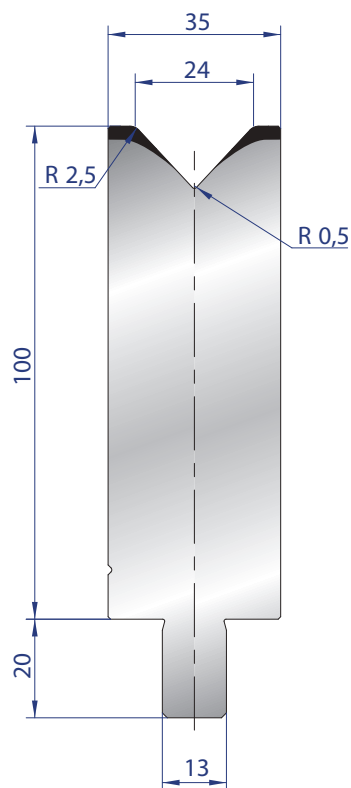

25-30	
35-40 mm	1,1 kg
45-50	
100 mm	2,8 kg
200 mm	5,6 kg
300 mm	8,4 kg
500 mm	14,0 kg
550 mm	15,4 kg
FRAZ. B / SECT. B	
1050 mm	29,4 kg
FRAZ. B / SECT. B	
1250 mm	35,0 kg
FRAZ. B / SECT. B	
2050 mm	57,4 kg
FRAZ. B / SECT. B	
2550 mm	71,4 kg
FRAZ. B / SECT. B	
3050 mm	85,4 kg
FRAZ. B / SECT. B	
4050 mm	113,4 kg
FRAZ. B / SECT. B	

3129

Mat = C45
Max T/m = 100
 $\alpha = 86^\circ$

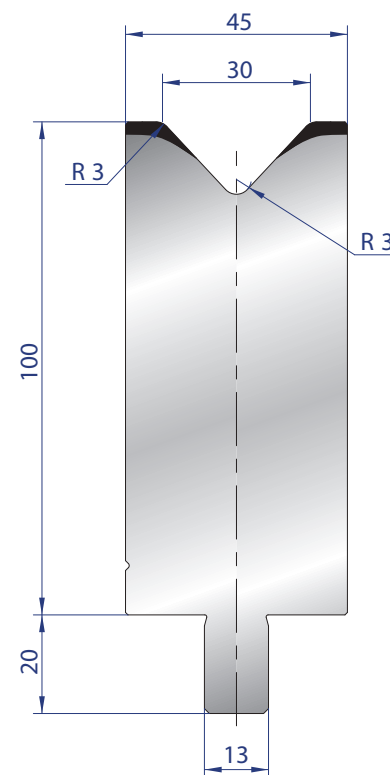

25-30	
35-40 mm	1,4 kg
45-50	
100 mm	3,6 kg
200 mm	7,2 kg
300 mm	10,8 kg
500 mm	18,0 kg
550 mm	18,0 kg
FRAZ. B / SECT. B	
1050 mm	37,8 kg
FRAZ. B / SECT. B	
1250 mm	45,0 kg
FRAZ. B / SECT. B	
2050 mm	73,8 kg
FRAZ. B / SECT. B	
2550 mm	91,8 kg
FRAZ. B / SECT. B	
3050 mm	109,8 kg
FRAZ. B / SECT. B	
4050 mm	145,8 kg
FRAZ. B / SECT. B	

3130

Mat = C45
Max T/m = 100
 $\alpha = 86^\circ$

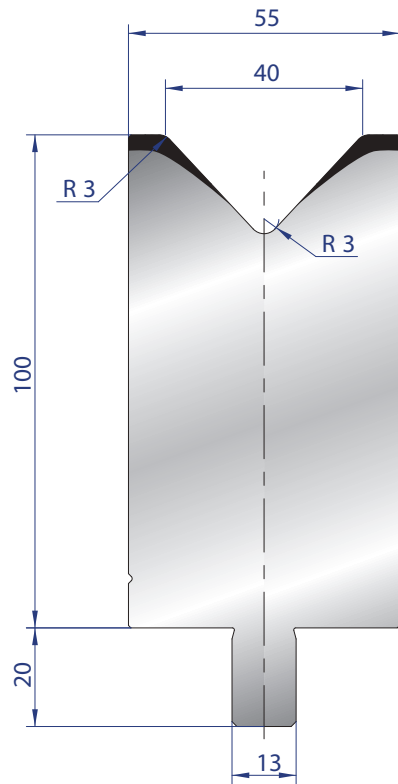

25-30	
35-40 mm	1,7 kg
45-50	
100 mm	4,2 kg
200 mm	8,4 kg
300 mm	12,6 kg
500 mm	21,0 kg
550 mm	21,0 kg
FRAZ. / SECT.	
1050 mm	44,1 kg
FRAZ. B / SECT. B	
1250 mm	52,5 kg
FRAZ. B / SECT. B	
2050 mm	84,0 kg
FRAZ. B / SECT. B	
2550 mm	104,5 kg
FRAZ. B / SECT. B	
3050 mm	125,0 kg
FRAZ. B / SECT. B	
4050 mm	166,0 kg
FRAZ. B / SECT. B	

3131

Mat = C45
Max T/m = 100
 $\alpha = 86^\circ$

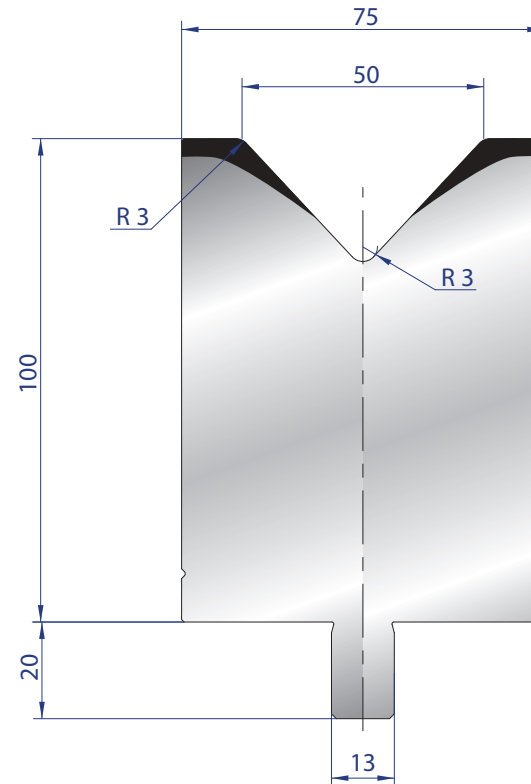

25-30	
35-40 mm	2,2 kg
45-50	
100 mm	5,6 kg
200 mm	11,2 kg
300 mm	16,8 kg
500 mm	28,0 kg
550 mm	28,0 kg
SEKT.	
1050 mm	58,8 kg
SEKT. B	
1250 mm	70,0 kg
SEKT. B	
2050 mm	114,8 kg
SEKT. B	
2550 mm	142,8 kg
SEKT. B	
3050 mm	170,8 kg
SEKT. B	
4050 mm	226,8 kg
SEKT. B	

3132

Mat = C45
Max T/m = 100
 $\alpha = 86^\circ$





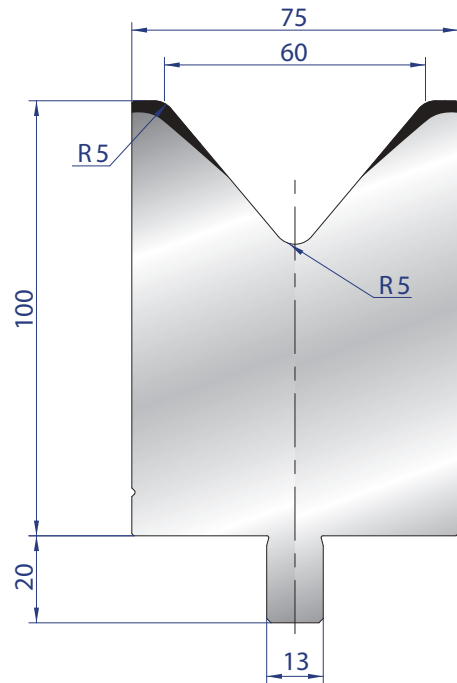

25-30	
35-40 mm	2,0 kg
45-50	
100 mm	5,2 kg
200 mm	10,4 kg
300 mm	15,6 kg
500 mm	26,0 kg
550 mm	28,6 kg
FRAZ. / SECT.	
1050 mm	54,6 kg
FRAZ. B / SECT. B	
1250 mm	65,0 kg
FRAZ. B / SECT. B	
2050 mm	106,6 kg
FRAZ. B / SECT. B	
2550 mm	132,6 kg
FRAZ. B / SECT. B	
3050 mm	158,6 kg
FRAZ. B / SECT. B	
4050 mm	210,6 kg
FRAZ. B / SECT. B	

3133

Mat = C45
Max T/m = 100
 $\alpha = 80^\circ$

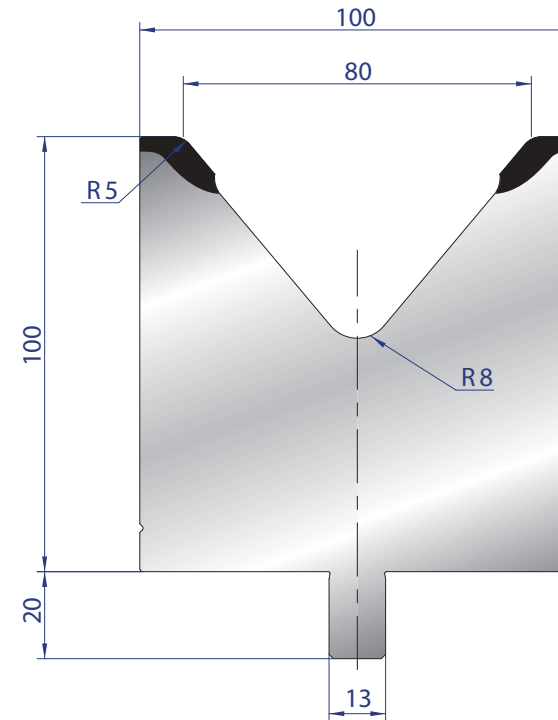

25-30	
35-40 mm	2,5 kg
45-50	
100 mm	6,4 kg
200 mm	12,8 kg
300 mm	19,2 kg
500 mm	32,0 kg
550 mm	35,2 kg
FRAZ. / SECT.	
1050 mm	67,2 kg
FRAZ. B / SECT. B	
1250 mm	80,0 kg
FRAZ. B / SECT. B	
2050 mm	131,2 kg
FRAZ. B / SECT. B	
2550 mm	163,2 kg
FRAZ. B / SECT. B	
3050 mm	195,2 kg
FRAZ. B / SECT. B	
4050 mm	259,2 kg
FRAZ. B / SECT. B	

3134

Mat = C45
Max T/m = 100
 $\alpha = 80^\circ$



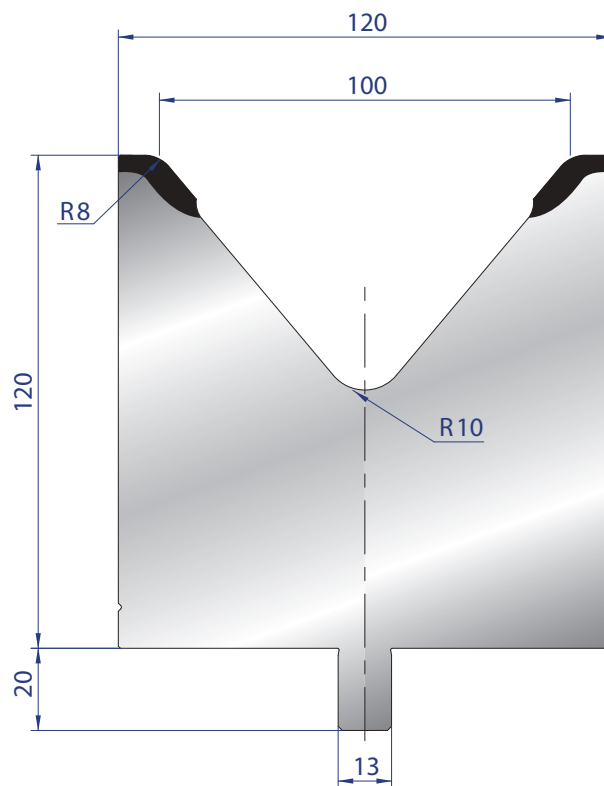

25-30	
35-40 mm	3,6 kg
45-50	
100 mm	9,0 kg
200 mm	18,0 kg
300 mm	27,0 kg
500 mm	45,0 kg
550 mm	49,5 kg
FRAZ. / SECT.	
1050 mm	44,5 kg
FRAZ. B / SECT. B	
1250 mm	112,5 kg
FRAZ. B / SECT. B	
2050 mm	184,5 kg
FRAZ. B / SECT. B	
2550 mm	229,5 kg
FRAZ. B / SECT. B	
3050 mm	274,5 kg
FRAZ. B / SECT. B	
4050 mm	364,5 kg
FRAZ. B / SECT. B	

3135

Mat = C45
Max T/m = 100
 $\alpha = 80^\circ$

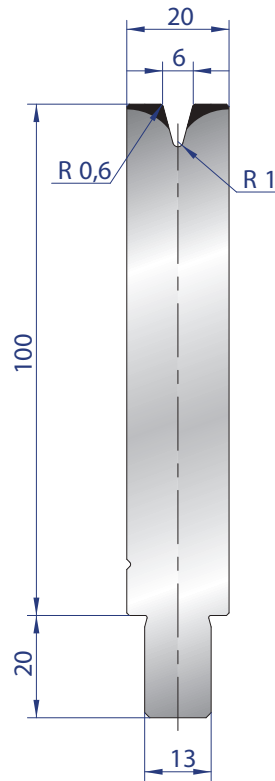

25-30	
35-40 mm	0,6 kg
45-50	
100 mm	1,8 kg
200 mm	3,6 kg
300 mm	5,4 kg
500 mm	8,7 kg
550 mm	9,6 kg
FRAZ. / SECT.	
1050 mm	18,9 kg
FRAZ. B / SECT. B	
1250 mm	22,5 kg
FRAZ. B / SECT. B	
2050 mm	36,9 kg
FRAZ. B / SECT. B	
2550 mm	45,9 kg
FRAZ. B / SECT. B	
3050 mm	54,9 kg
FRAZ. B / SECT. B	
4050 mm	72,9 kg
FRAZ. B / SECT. B	

3136

Mat = C45
Max T/m = 50
 $\alpha = 30^\circ$

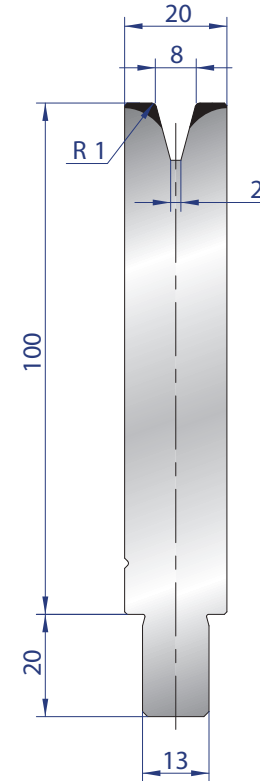

25-30	
35-40 mm	0,6 kg
45-50	
100 mm	1,8 kg
200 mm	3,6 kg
300 mm	5,4 kg
500 mm	8,7 kg
550 mm	9,6 kg
FRAZ. / SECT.	
1050 mm	18,9 kg
FRAZ. B / SECT. B	
1250 mm	22,5 kg
FRAZ. B / SECT. B	
2050 mm	36,9 kg
FRAZ. B / SECT. B	
2550 mm	45,9 kg
FRAZ. B / SECT. B	
3050 mm	54,9 kg
FRAZ. B / SECT. B	
4050 mm	72,9 kg
FRAZ. B / SECT. B	

3137

Mat = C45
Max T/m = 50
 $\alpha = 30^\circ$



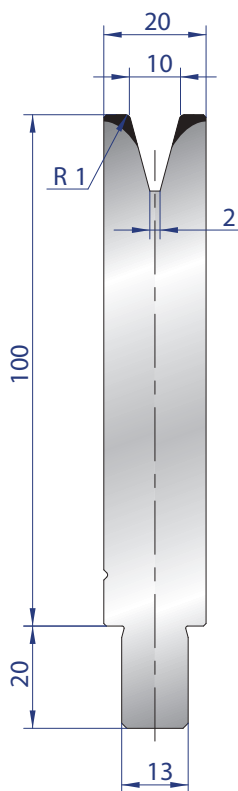

25-30	
35-40 mm	0,6 kg
45-50	
100 mm	1,8 kg
200 mm	3,6 kg
300 mm	5,4 kg
500 mm	8,7 kg
550 mm	9,6 kg
FRAZ. / SECT. B	
1050 mm	18,9 kg
FRAZ. B / SECT. B	
1250 mm	22,5 kg
FRAZ. B / SECT. B	
2050 mm	36,9 kg
FRAZ. B / SECT. B	
2550 mm	45,9 kg
FRAZ. B / SECT. B	
3050 mm	54,9 kg
FRAZ. B / SECT. B	
4050 mm	72,9 kg
FRAZ. B / SECT. B	

3138

Mat = C45
Max T/m = 50
 $\alpha = 30^\circ$

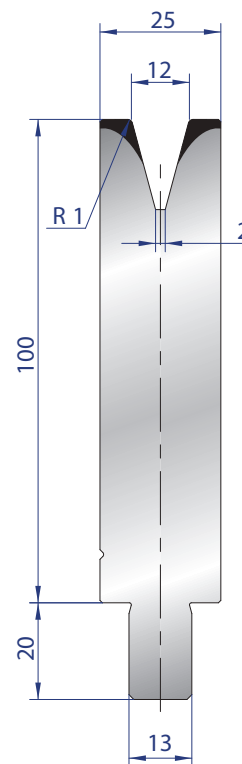

25-30	
35-40 mm	0,8 kg
45-50	
100 mm	2,0 kg
200 mm	4,1 kg
300 mm	6,2 kg
500 mm	10,2 kg
550 mm	11,3 kg
FRAZ. / SECT. B	
1050 mm	21,0 kg
FRAZ. B / SECT. B	
1250 mm	25,0 kg
FRAZ. B / SECT. B	
2050 mm	41,0 kg
FRAZ. B / SECT. B	
2550 mm	51,0 kg
FRAZ. B / SECT. B	
3050 mm	61,0 kg
FRAZ. B / SECT. B	
4050 mm	81,0 kg
FRAZ. B / SECT. B	

3139

Mat = C45
Max T/m = 50
 $\alpha = 30^\circ$

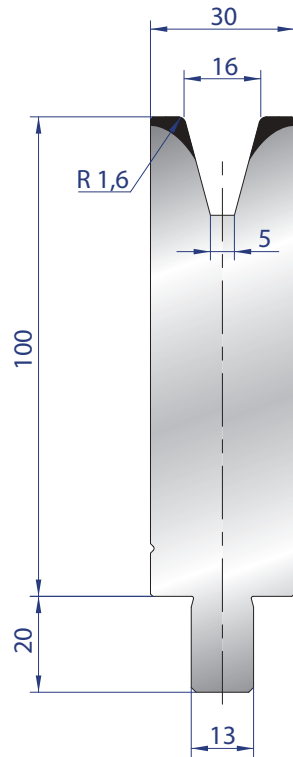

25-30	
35-40 mm	0,9 kg
45-50	
100 mm	2,4 kg
200 mm	4,8 kg
300 mm	7,2 kg
500 mm	11,8 kg
550 mm	13,0 kg
FRAZ. B / SECT. B	
1050 mm	25,2 kg
FRAZ. B / SECT. B	
1250 mm	30,0 kg
FRAZ. B / SECT. B	
2050 mm	49,2 kg
FRAZ. B / SECT. B	
2550 mm	63,7 kg
FRAZ. B / SECT. B	
3050 mm	73,2 kg
FRAZ. B / SECT. B	
4050 mm	97,2 kg
FRAZ. B / SECT. B	

3140

Mat = C45
Max T/m = 50
 $\alpha = 30^\circ$

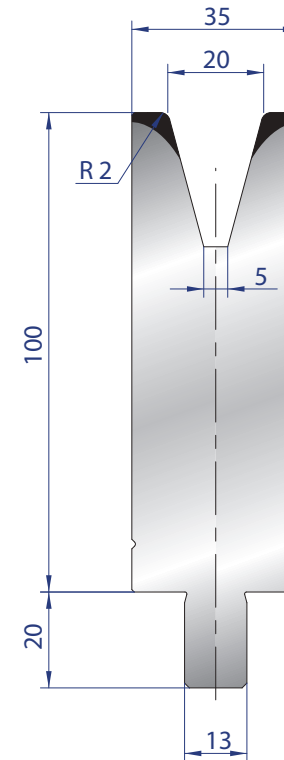

25-30	
35-40 mm	1,0 kg
45-50	
100 mm	2,6 kg
200 mm	5,2 kg
300 mm	7,8 kg
500 mm	13,0 kg
550 mm	13,0 kg
FRAZ. B / SECT. B	
1050 mm	27,3 kg
FRAZ. B / SECT. B	
1250 mm	32,5 kg
FRAZ. B / SECT. B	
2050 mm	53,3 kg
FRAZ. B / SECT. B	
2550 mm	66,3 kg
FRAZ. B / SECT. B	
3050 mm	79,3 kg
FRAZ. B / SECT. B	
4050 mm	105,3 kg
FRAZ. B / SECT. B	

3141

Mat = C45
Max T/m = 55
 $\alpha = 30^\circ$



MATRICI 1V H100 - 30° / 1V DIES H100 - 30°

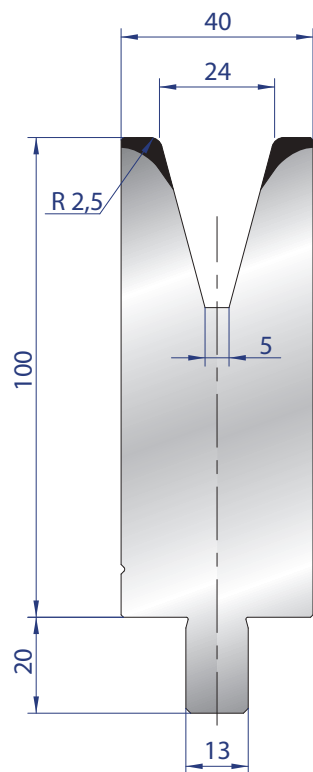

25-30	
35-40 mm	1,2 kg
45-50	
100 mm	3,0 kg
200 mm	6,0 kg
300 mm	9,0 kg
500 mm	15,0 kg
550 mm	15,0 kg
FRAZ. / SECT.	
1050 mm	31,5 kg
FRAZ. B / SECT. B	
1250 mm	37,5 kg
FRAZ. B / SECT. B	
2050 mm	61,5 kg
FRAZ. B / SECT. B	
2550 mm	76,5 kg
FRAZ. B / SECT. B	
3050 mm	91,5 kg
FRAZ. B / SECT. B	
4050 mm	121,5 kg
FRAZ. B / SECT. B	

3142

Mat = C45

Max T/m = 55

$\alpha = 30^\circ$



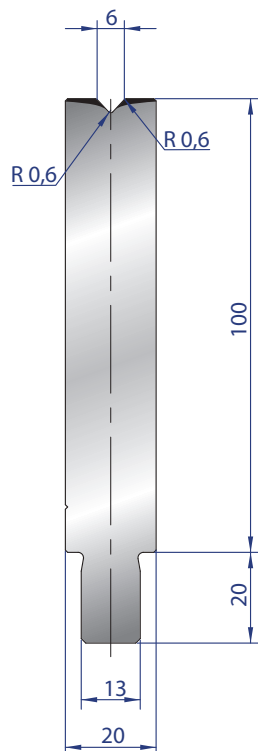

25-30	
35-40 mm	0,6 kg
45-50	
100 mm	1,8 kg
200 mm	3,6 kg
300 mm	5,4 kg
500 mm	8,7 kg
550 mm	9,6 kg
FRAZ. / SECT.	
1050 mm	18,9 kg
FRAZ. B / SECT. B	
1250 mm	22,5 kg
FRAZ. B / SECT. B	
2050 mm	36,9 kg
FRAZ. B / SECT. B	
2550 mm	45,9 kg
FRAZ. B / SECT. B	
3050 mm	54,9 kg
FRAZ. B / SECT. B	
4050 mm	72,9 kg
FRAZ. B / SECT. B	

3200

Mat = 42CrMo4
bonificato / tempered
Max T/m = 100
α = 86°

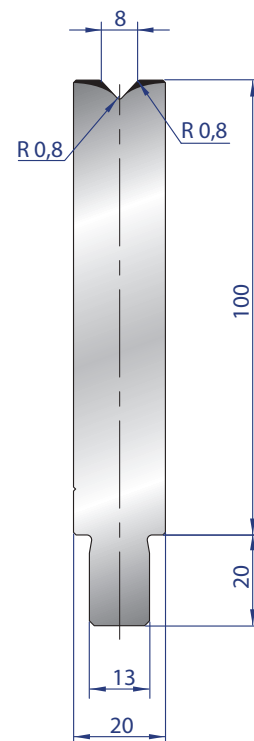

25-30	
35-40 mm	0,6 kg
45-50	
100 mm	1,8 kg
200 mm	3,6 kg
300 mm	5,4 kg
500 mm	8,7 kg
550 mm	9,6 kg
FRAZ. / SECT.	
1050 mm	18,9 kg
FRAZ. B / SECT. B	
1250 mm	22,5 kg
FRAZ. B / SECT. B	
2050 mm	36,9 kg
FRAZ. B / SECT. B	
2550 mm	45,9 kg
FRAZ. B / SECT. B	
3050 mm	54,9 kg
FRAZ. B / SECT. B	
4050 mm	72,9 kg
FRAZ. B / SECT. B	

3201

Mat = 42CrMo4
bonificato / tempered
Max T/m = 100
α = 86°



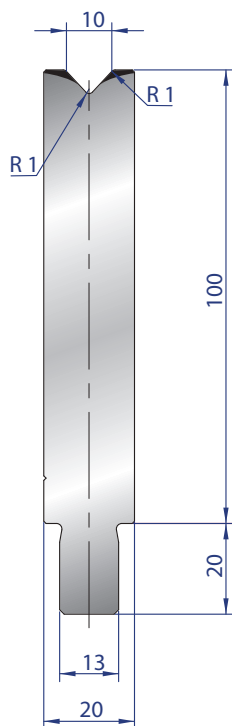

25-30	
35-40 mm	0,6 kg
45-50	
100 mm	1,8 kg
200 mm	3,6 kg
300 mm	5,4 kg
500 mm	8,7 kg
550 mm	9,6 kg
FRAZ. / SECT.	
1050 mm	18,9 kg
FRAZ. B / SECT. B	
1250 mm	22,5 kg
FRAZ. B / SECT. B	
2050 mm	36,9 kg
FRAZ. B / SECT. B	
2550 mm	45,9 kg
FRAZ. B / SECT. B	
3050 mm	54,9 kg
FRAZ. B / SECT. B	
4050 mm	72,9 kg
FRAZ. B / SECT. B	

3202

Mat = 42CrMo4
bonificato / tempered
Max T/m = 100
α = 86°

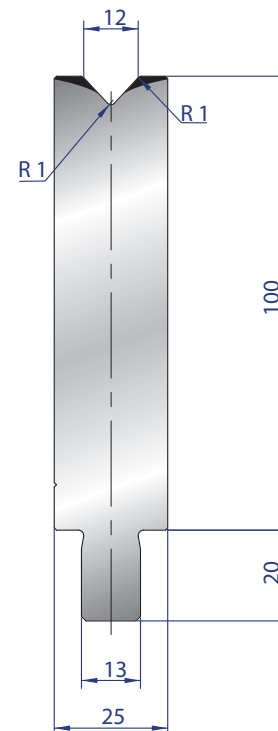

25-30	
35-40 mm	0,8 kg
45-50	
100 mm	2,0 kg
200 mm	4,1 kg
300 mm	6,2 kg
500 mm	10,2 kg
550 mm	11,3 kg
FRAZ. / SECT.	
1050 mm	21,0 kg
FRAZ. B / SECT. B	
1250 mm	25,0 kg
FRAZ. B / SECT. B	
2050 mm	41,0 kg
FRAZ. B / SECT. B	
2550 mm	51,0 kg
FRAZ. B / SECT. B	
3050 mm	61,0 kg
FRAZ. B / SECT. B	
4050 mm	81,0 kg
FRAZ. B / SECT. B	

3203

Mat = 42CrMo4
bonificato / tempered
Max T/m = 100
α = 86°

TRUMPF
STYLE





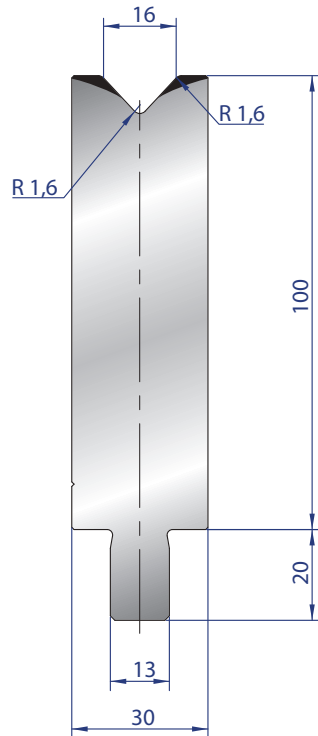

25-30	
35-40 mm	1,0 kg
45-50	
100 mm	2,5 kg
200 mm	5,0 kg
300 mm	7,5 kg
500 mm	12,5 kg
550 mm	13,8 kg
FRAZ. B / SECT. B	
1050 mm	26,2 kg
FRAZ. B / SECT. B	
1250 mm	31,2 kg
FRAZ. B / SECT. B	
2050 mm	51,2 kg
FRAZ. B / SECT. B	
2550 mm	63,7 kg
FRAZ. B / SECT. B	
3050 mm	76,2 kg
FRAZ. B / SECT. B	
4050 mm	101,2 kg
FRAZ. B / SECT. B	

3204

Mat = 42CrMo4
bonificato / tempered
Max T/m = 100
α = 86°

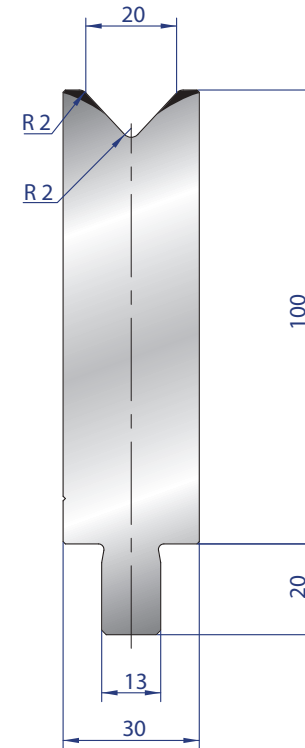

25-30	
35-40 mm	1,0 kg
45-50	
100 mm	2,5 kg
200 mm	5,0 kg
300 mm	7,5 kg
500 mm	12,5 kg
550 mm	13,8 kg
FRAZ. B / SECT. B	
1050 mm	26,2 kg
FRAZ. B / SECT. B	
1250 mm	31,2 kg
FRAZ. B / SECT. B	
2050 mm	51,2 kg
FRAZ. B / SECT. B	
2550 mm	63,7 kg
FRAZ. B / SECT. B	
3050 mm	76,2 kg
FRAZ. B / SECT. B	
4050 mm	101,2 kg
FRAZ. B / SECT. B	

3205

Mat = 42CrMo4
bonificato / tempered
Max T/m = 100
α = 86°



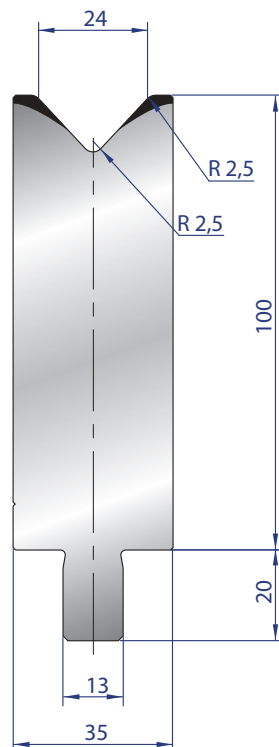

25-30	
35-40 mm	1,1 kg
45-50	
100 mm	2,8 kg
200 mm	5,6 kg
300 mm	8,4 kg
500 mm	14,0 kg
550 mm	15,4 kg
FRAZ. / SECT.	
1050 mm	29,4 kg
FRAZ. B / SECT. B	
1250 mm	35,0 kg
FRAZ. B / SECT. B	
2050 mm	57,4 kg
FRAZ. B / SECT. B	
2550 mm	71,4 kg
FRAZ. B / SECT. B	
3050 mm	85,4 kg
FRAZ. B / SECT. B	
4050 mm	113,4 kg
FRAZ. B / SECT. B	

3215

Mat = 42CrMo4
bonificato / tempered
Max T/m = 100
α = 86°

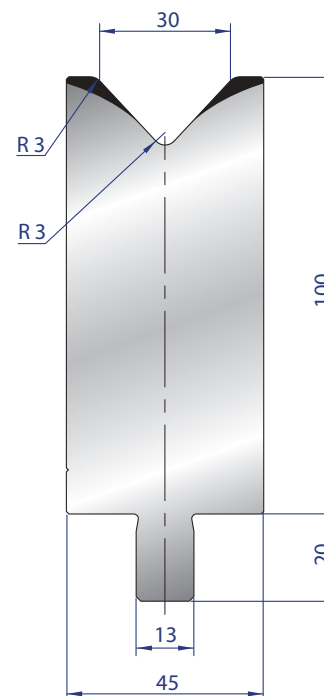

25-30	
35-40 mm	1,4 kg
45-50	
100 mm	3,5 kg
200 mm	7,0 kg
300 mm	10,5 kg
500 mm	17,5 kg
550 mm	19,3 kg
FRAZ. / SECT.	
1050 mm	36,7 kg
FRAZ. B / SECT. B	
1250 mm	43,7 kg
FRAZ. B / SECT. B	
2050 mm	71,7 kg
FRAZ. B / SECT. B	
2550 mm	89,2 kg
FRAZ. B / SECT. B	
3050 mm	106,7 kg
FRAZ. B / SECT. B	
4050 mm	141,7 kg
FRAZ. B / SECT. B	

3216

Mat = 42CrMo4
bonificato / tempered
Max T/m = 100
α = 86°

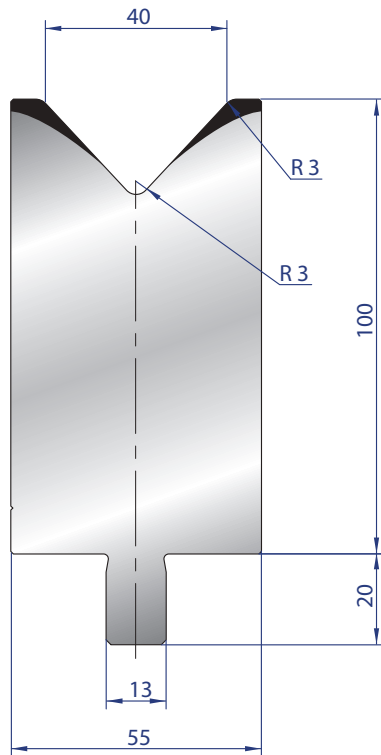

25-30	
35-40 mm	1,6 kg
45-50	
100 mm	4,0 kg
200 mm	8,0 kg
300 mm	12,0 kg
500 mm	20,0 kg
550 mm	22,0 kg
FRAZ. / SECT.	
1050 mm	42,0 kg
FRAZ. B / SECT. B	
1250 mm	50,0 kg
FRAZ. B / SECT. B	
2050 mm	82,0 kg
FRAZ. B / SECT. B	
2550 mm	102,0 kg
FRAZ. B / SECT. B	
3050 mm	122,0 kg
FRAZ. B / SECT. B	
4050 mm	162,0 kg
FRAZ. B / SECT. B	

3217

Mat = 42CrMo4
bonificato / tempered
Max T/m = 120
α = 86°

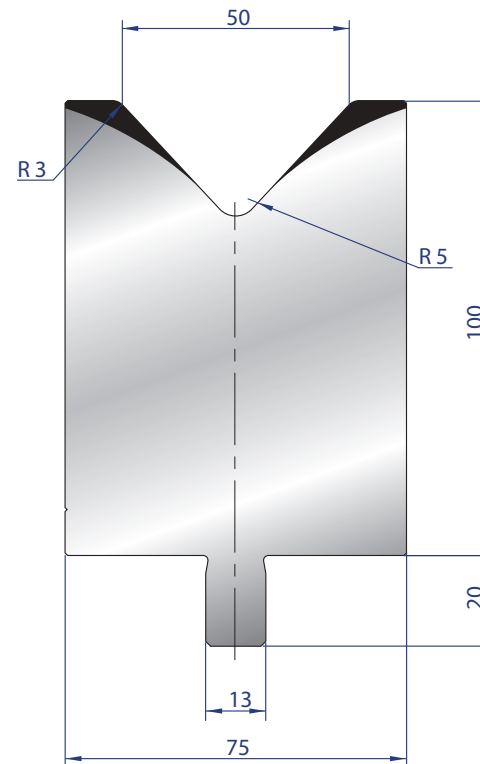

25-30	
35-40 mm	2,2 kg
45-50	
100 mm	5,5 kg
200 mm	11,0 kg
300 mm	16,5 kg
500 mm	27,5 kg
550 mm	30,3 kg
FRAZ. / SECT.	
1050 mm	57,7 kg
FRAZ. B / SECT. B	
1250 mm	68,7 kg
FRAZ. B / SECT. B	
2050 mm	112,7 kg
FRAZ. B / SECT. B	
2550 mm	140,2 kg
FRAZ. B / SECT. B	
3050 mm	167,7 kg
FRAZ. B / SECT. B	
4050 mm	222,7 kg
FRAZ. B / SECT. B	

3218

Mat = 42CrMo4
bonificato / tempered
Max T/m = 150
α = 86°



MATRICI 1V H100 - **86°** / 1V DIES H100 - **86°**

TRUMPF
STYLE

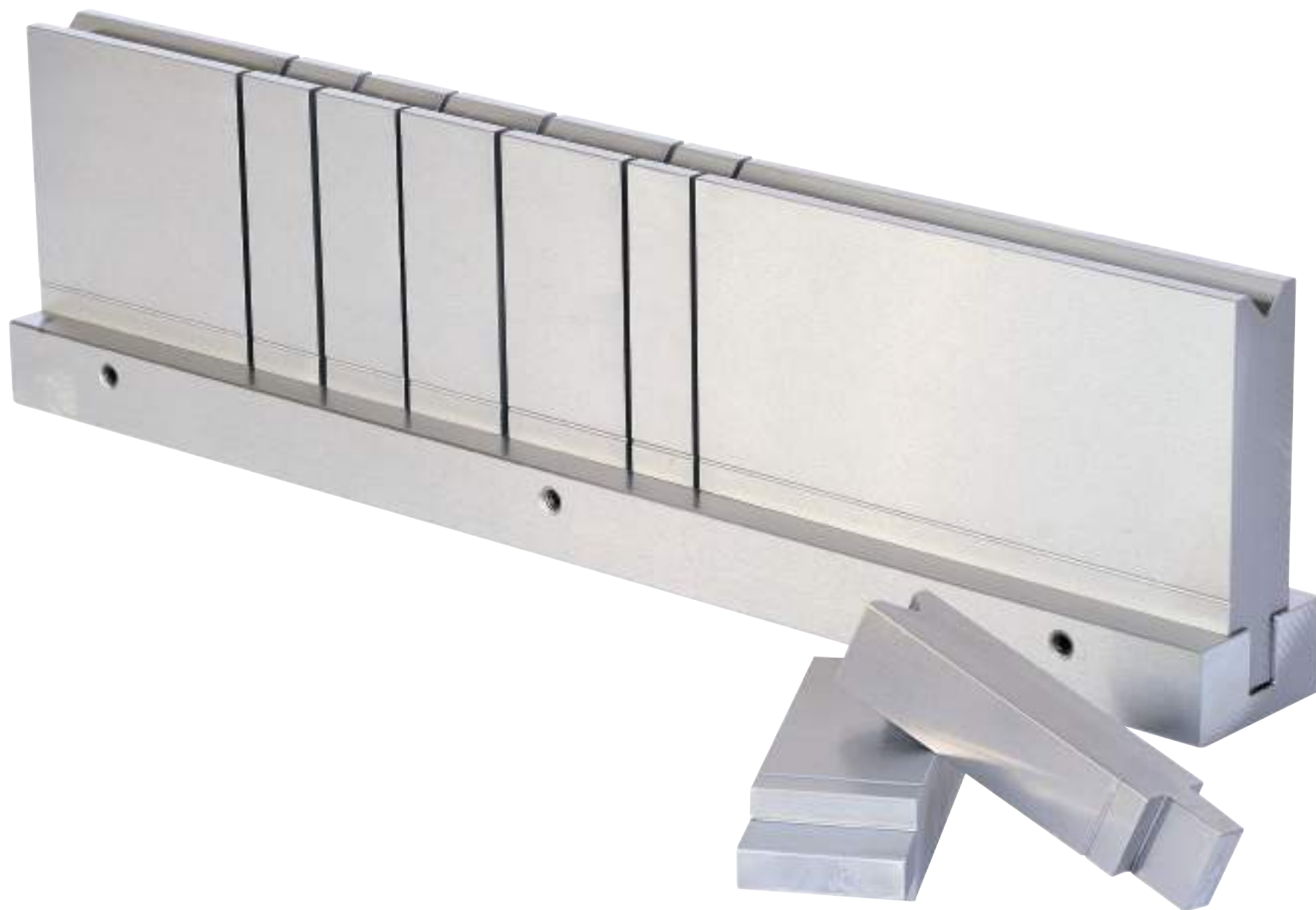

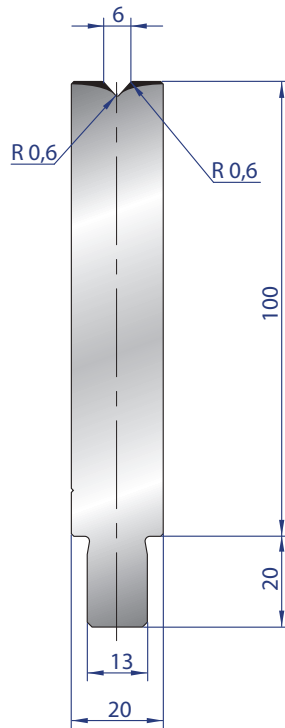

25-30	
35-40 mm	0,6 kg
45-50	
100 mm	1,8 kg
200 mm	3,6 kg
300 mm	5,4 kg
500 mm	8,7 kg
550 mm	9,6 kg
FRAZ. / SECT.	
1050 mm	18,9 kg
FRAZ. B / SECT. B	
1250 mm	22,5 kg
FRAZ. B / SECT. B	
2050 mm	36,9 kg
FRAZ. B / SECT. B	
2550 mm	45,9 kg
FRAZ. B / SECT. B	
3050 mm	54,9 kg
FRAZ. B / SECT. B	
4050 mm	72,9 kg
FRAZ. B / SECT. B	

3225

Mat = 42CrMo4
bonificato / tempered
Max T/m = 130
α = 84°

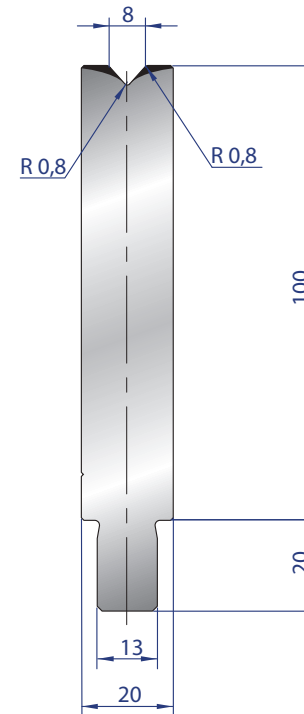

25-30	
35-40 mm	0,6 kg
45-50	
100 mm	1,8 kg
200 mm	3,6 kg
300 mm	5,4 kg
500 mm	8,7 kg
550 mm	9,6 kg
FRAZ. / SECT.	
1050 mm	18,9 kg
FRAZ. B / SECT. B	
1250 mm	22,5 kg
FRAZ. B / SECT. B	
2050 mm	36,9 kg
FRAZ. B / SECT. B	
2550 mm	45,9 kg
FRAZ. B / SECT. B	
3050 mm	54,9 kg
FRAZ. B / SECT. B	
4050 mm	72,9 kg
FRAZ. B / SECT. B	

3226

Mat = 42CrMo4
bonificato / tempered
Max T/m = 100
α = 84°



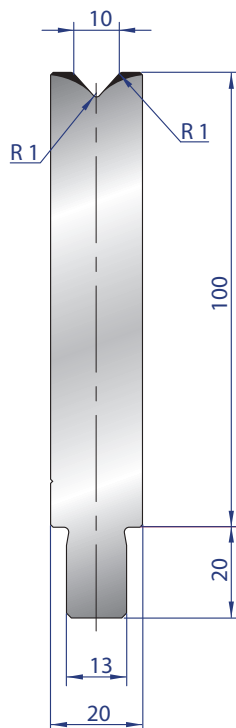

25-30	
35-40 mm	0,6 kg
45-50	
100 mm	1,8 kg
200 mm	3,6 kg
300 mm	5,4 kg
500 mm	8,7 kg
550 mm	9,6 kg
1050 mm	18,9 kg
1250 mm	22,5 kg
2050 mm	36,9 kg
2550 mm	45,9 kg
3050 mm	54,9 kg
4050 mm	72,9 kg

3227

Mat = 42CrMo4
bonificato / tempered
Max T/m = 100
α = 84°

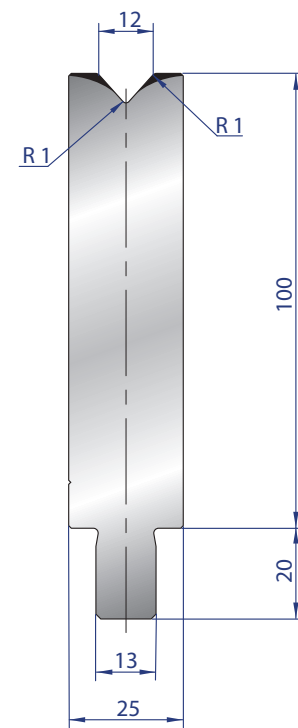

25-30	
35-40 mm	0,8 kg
45-50	
100 mm	2,0 kg
200 mm	4,1 kg
300 mm	6,2 kg
500 mm	10,2 kg
550 mm	11,3 kg
1050 mm	21,0 kg
1250 mm	25,0 kg
2050 mm	41,0 kg
2550 mm	51,0 kg
3050 mm	61,0 kg
4050 mm	81,0 kg

3228

Mat = 42CrMo4
bonificato / tempered
Max T/m = 100
α = 84°

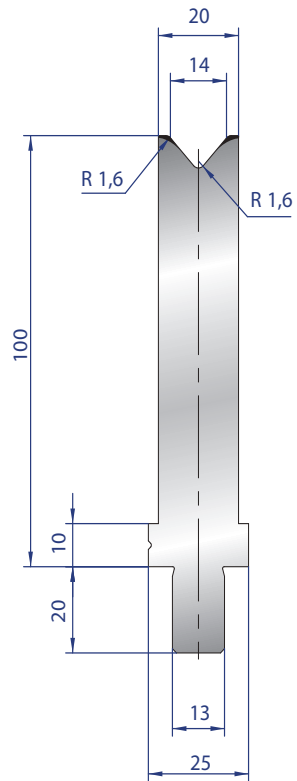

25-30	0,6 kg
35-40 mm	
45-50	
100 mm	1,8 kg
200 mm	3,5 kg
300 mm	5,3 kg
500 mm	8,8 kg
550 mm	9,7 kg
FRAZ. / SECT.	
1050 mm	17,6 kg
FRAZ. B / SECT. B	
1250 mm	21,1 kg
FRAZ. B / SECT. B	
2050 mm	35,2 kg
FRAZ. B / SECT. B	
2550 mm	44,0 kg
FRAZ. B / SECT. B	
3050 mm	52,8 kg
FRAZ. B / SECT. B	
4050 mm	70,4 kg
FRAZ. B / SECT. B	

3244

Mat = 42CrMo4
bonificato / tempered
Max T/m = 90
α = 84°

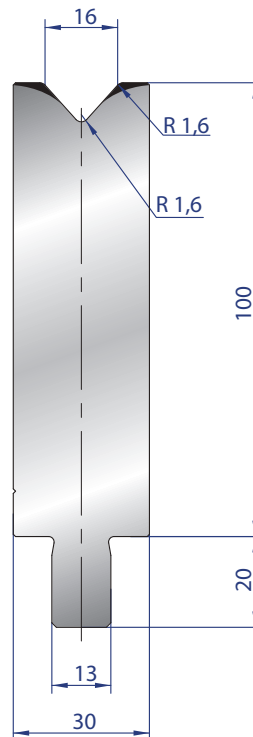

25-30	1,0 kg
35-40 mm	
45-50	
100 mm	2,5 kg
200 mm	5,0 kg
300 mm	7,5 kg
500 mm	12,5 kg
550 mm	13,8 kg
FRAZ. / SECT.	
1050 mm	26,2 kg
FRAZ. B / SECT. B	
1250 mm	31,2 kg
FRAZ. B / SECT. B	
2050 mm	51,2 kg
FRAZ. B / SECT. B	
2550 mm	63,7 kg
FRAZ. B / SECT. B	
3050 mm	76,2 kg
FRAZ. B / SECT. B	
4050 mm	101,2 kg
FRAZ. B / SECT. B	

3229

Mat = 42CrMo4
bonificato / tempered
Max T/m = 100
α = 84°

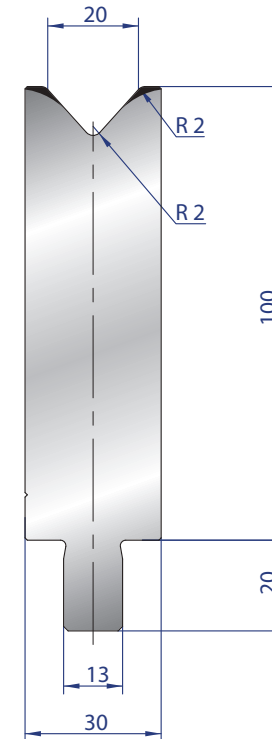

25-30	1,0 kg
35-40 mm	
45-50	
100 mm	2,5 kg
200 mm	5,0 kg
300 mm	7,5 kg
500 mm	12,5 kg
550 mm	13,8 kg
FRAZ. / SECT.	
1050 mm	26,2 kg
FRAZ. B / SECT. B	
1250 mm	31,2 kg
FRAZ. B / SECT. B	
2050 mm	51,2 kg
FRAZ. B / SECT. B	
2550 mm	63,7 kg
FRAZ. B / SECT. B	
3050 mm	76,2 kg
FRAZ. B / SECT. B	
4050 mm	101,2 kg
FRAZ. B / SECT. B	

3230

Mat = 42CrMo4
bonificato / tempered
Max T/m = 100
α = 84°



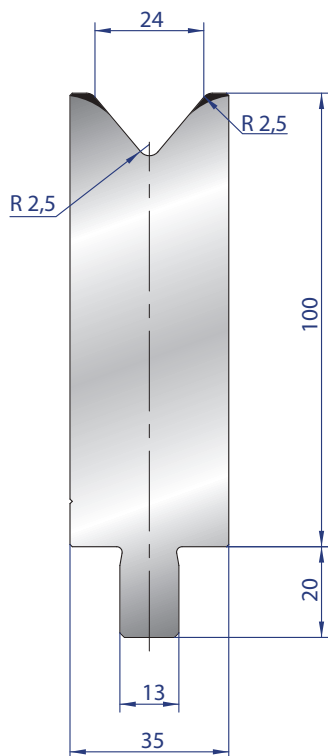

25-30	
35-40 mm	1,1 kg
45-50	
100 mm	2,8 kg
200 mm	5,6 kg
300 mm	8,4 kg
500 mm	14,0 kg
550 mm	15,4 kg
FRAZ. / SECT.	
1050 mm	29,4 kg
FRAZ. B / SECT. B	
1250 mm	35,0 kg
FRAZ. B / SECT. B	
2050 mm	57,4 kg
FRAZ. B / SECT. B	
2550 mm	71,4 kg
FRAZ. B / SECT. B	
3050 mm	85,4 kg
FRAZ. B / SECT. B	
4050 mm	113,4 kg
FRAZ. B / SECT. B	

3231

Mat = 42CrMo4
bonificato / tempered
Max T/m = 100
α = 80°

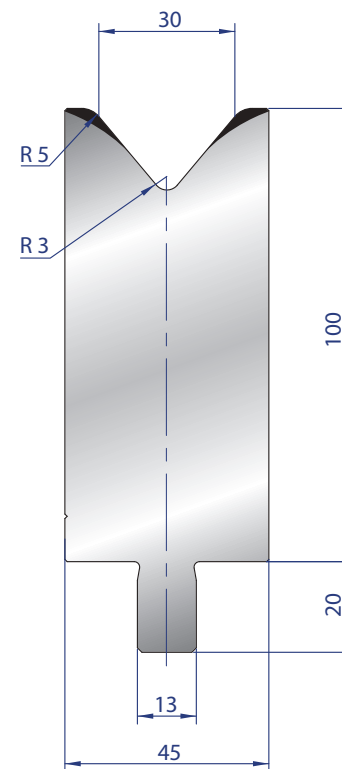

25-30	
35-40 mm	1,4 kg
45-50	
100 mm	3,5 kg
200 mm	7,0 kg
300 mm	10,5 kg
500 mm	17,5 kg
550 mm	19,3 kg
FRAZ. / SECT.	
1050 mm	36,7 kg
FRAZ. B / SECT. B	
1250 mm	43,7 kg
FRAZ. B / SECT. B	
2050 mm	71,7 kg
FRAZ. B / SECT. B	
2550 mm	89,2 kg
FRAZ. B / SECT. B	
3050 mm	106,7 kg
FRAZ. B / SECT. B	
4050 mm	141,7 kg
FRAZ. B / SECT. B	

3232

Mat = 42CrMo4
bonificato / tempered
Max T/m = 120
α = 80°

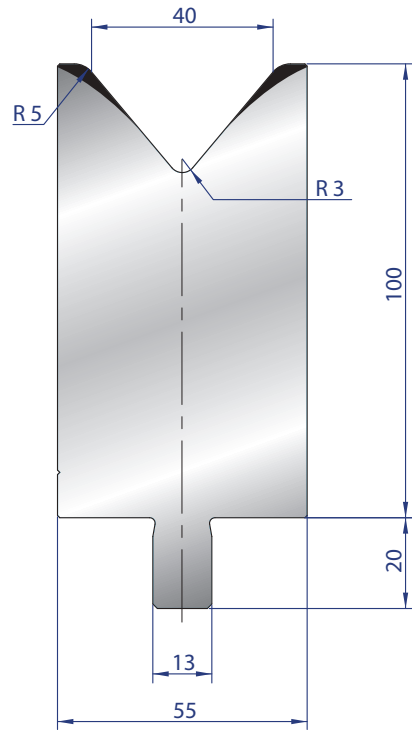

25-30	
35-40 mm	1,6 kg
45-50	
100 mm	4,1 kg
200 mm	8,2 kg
300 mm	12,3 kg
500 mm	20,6 kg
550 mm	22,7 kg
FRAZ. / SECT.	
1050 mm	43,0 kg
FRAZ. B / SECT. B	
1250 mm	51,2 kg
FRAZ. B / SECT. B	
2050 mm	84,0 kg
FRAZ. B / SECT. B	
2550 mm	104,5 kg
FRAZ. B / SECT. B	
3050 mm	125,0 kg
FRAZ. B / SECT. B	
4050 mm	166,0 kg
FRAZ. B / SECT. B	

3233

Mat = 42CrMo4
bonificato / tempered
Max T/m = 150
α = 80°

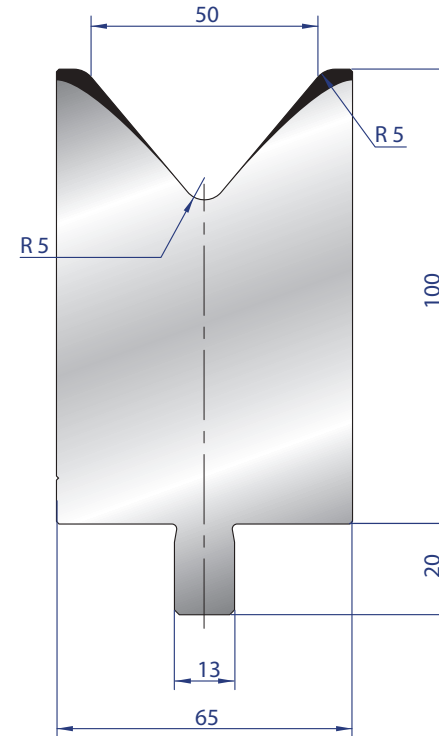

25-30	
35-40 mm	1,8 kg
45-50	
100 mm	4,6 kg
200 mm	9,2 kg
300 mm	13,8 kg
500 mm	23,0 kg
550 mm	25,3 kg
FRAZ. / SECT.	
1050 mm	48,3 kg
FRAZ. B / SECT. B	
1250 mm	57,5 kg
FRAZ. B / SECT. B	
2050 mm	94,3 kg
FRAZ. B / SECT. B	
2550 mm	117,3 kg
FRAZ. B / SECT. B	
3050 mm	140,3 kg
FRAZ. B / SECT. B	
4050 mm	186,3 kg
FRAZ. B / SECT. B	

3234

Mat = 42CrMo4
bonificato / tempered
Max T/m = 150
α = 80°



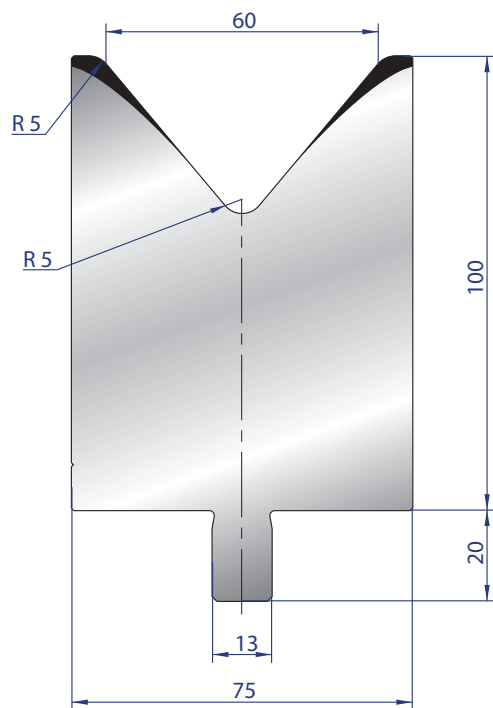

25-30	
35-40 mm	2,0 kg
45-50	
100 mm	5,2 kg
200 mm	10,4 kg
300 mm	15,6 kg
500 mm	26,0 kg
550 mm	28,6 kg
FRAZ. B / SECT. B	
1050 mm	54,6 kg
FRAZ. B / SECT. B	
1250 mm	65,0 kg
FRAZ. B / SECT. B	
2050 mm	106,6 kg
FRAZ. B / SECT. B	
2550 mm	132,6 kg
FRAZ. B / SECT. B	
3050 mm	158,6 kg
FRAZ. B / SECT. B	
4050 mm	210,6 kg
FRAZ. B / SECT. B	

3219

Mat = 42CrMo4
bonificato / tempered
Max T/m = 150
α = 80°

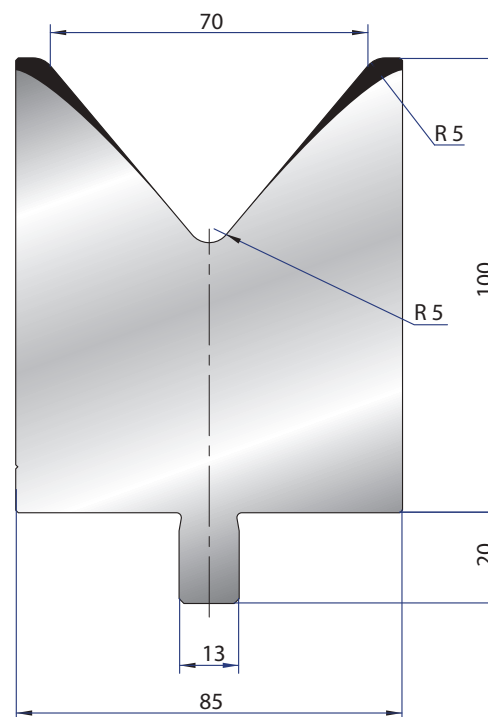

25-30	
35-40 mm	2,2 kg
45-50	
100 mm	5,6 kg
200 mm	11,2 kg
300 mm	16,8 kg
500 mm	28,0 kg
FRAZ. B / SECT. B	
1050 mm	58,8 kg
FRAZ. B / SECT. B	
1250 mm	70,0 kg
FRAZ. B / SECT. B	
2050 mm	114,8 kg
FRAZ. B / SECT. B	
2550 mm	142,8 kg
FRAZ. B / SECT. B	
3050 mm	170,8 kg
FRAZ. B / SECT. B	
4050 mm	226,8 kg
FRAZ. B / SECT. B	

3220

Mat = 42CrMo4
bonificato / tempered
Max T/m = 150
α = 80°

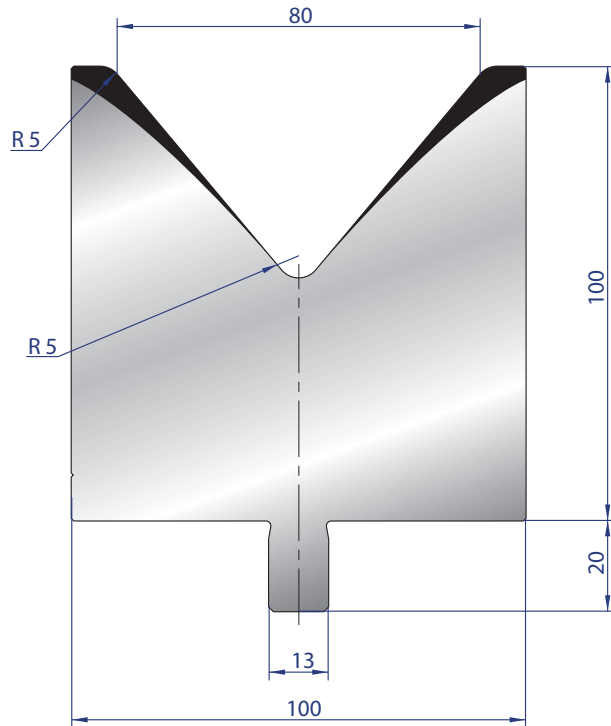

25-30	
35-40 mm	2,5 kg
45-50	
100 mm	6,4 kg
200 mm	12,8 kg
300 mm	19,2 kg
550 mm	35,2 kg
1050 mm	67,2 kg
1250 mm	80,0 kg
2050 mm	131,2 kg
2550 mm	163,2 kg
3050 mm	195,2 kg
4050 mm	259,2 kg

3221

Mat = 42CrMo4
bonificato / tempered
Max T/m = 150
α = 80°

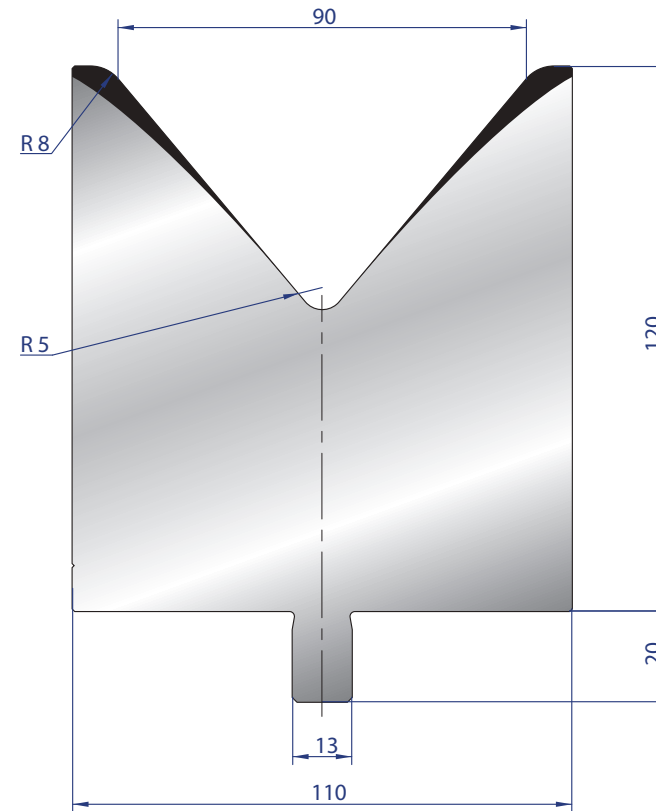

25-30	
35-40 mm	3,4 kg
45-50	
100 mm	8,5 kg
200 mm	17,0 kg
550 mm	46,7 kg
1050 mm	89,2 kg
1250 mm	106,2 kg
2050 mm	174,2 kg
2550 mm	216,7 kg
3050 mm	259,2 kg
4050 mm	344,2 kg

3222

Mat = 42CrMo4
bonificato / tempered
Max T/m = 150
α = 80°



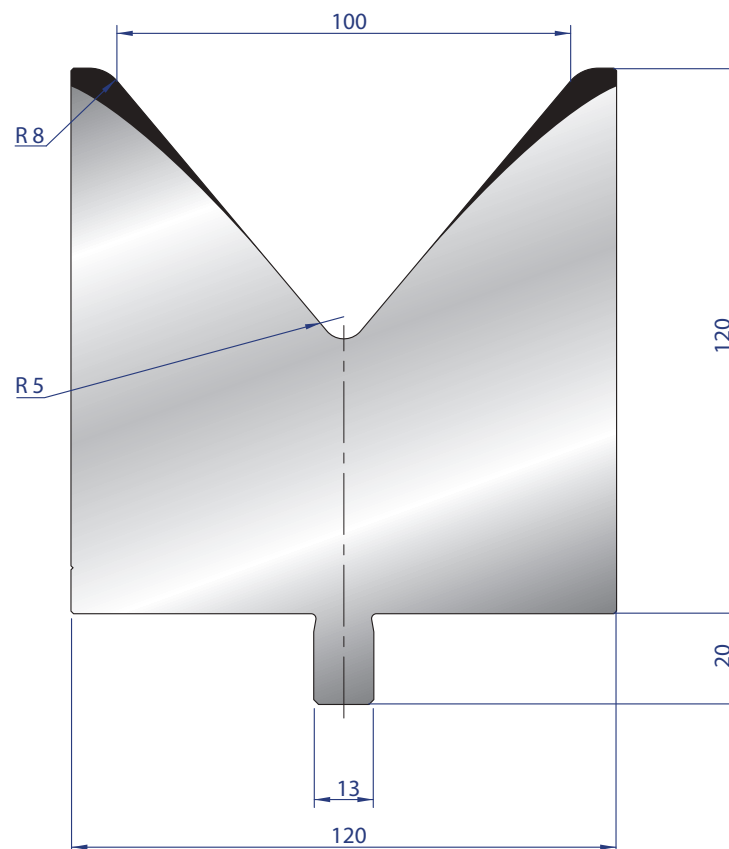

25-30	
35-40 mm	3,5 kg
45-50	
100 mm	8,9 kg
200 mm	17,8 kg
550 mm	48,9 kg
1050 mm	93,4 kg
1250 mm	111,2 kg
2050 mm	182,4 kg
2550 mm	226,9 kg
3050 mm	271,4 kg
4050 mm	360,4 kg

3223

Mat = 42CrMo4
bonificato / tempered

Max T/m = 150

α = 80°

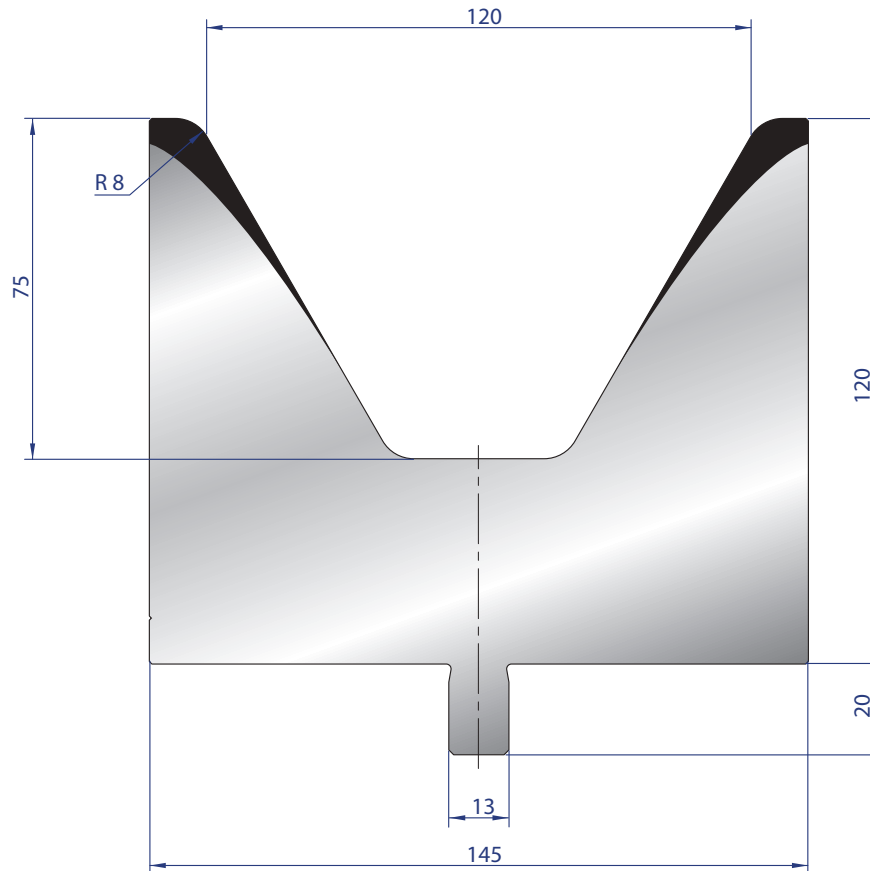

25-30	
35-40 mm	3,6 kg
45-50	
100 mm	9,1 kg
200 mm	18,2 kg
550 mm	50,0 kg
FRAZ. / SECT.	
1050 mm	95,5 kg
FRAZ. B / SECT. B	
1250 mm	113,7 kg
FRAZ. B / SECT. B	
2050 mm	186,5 kg
FRAZ. B / SECT. B	
2550 mm	232,0 kg
FRAZ. B / SECT. B	
3050 mm	277,5 kg
FRAZ. B / SECT. B	
4050 mm	368,5 kg
FRAZ. B / SECT. B	

3224

Mat = 42CrMo4
bonificato / tempered

Max T/m = 160

α = 60°



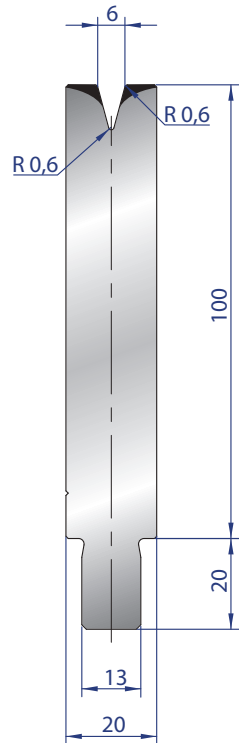

25-30	
35-40 mm	0,6 kg
45-50	
100 mm	1,8 kg
200 mm	3,6 kg
300 mm	5,4 kg
500 mm	8,7 kg
550 mm	9,6 kg
FRAZ. B / SECT. B	
1050 mm	18,9 kg
FRAZ. B / SECT. B	
1250 mm	22,5 kg
FRAZ. B / SECT. B	
2050 mm	36,9 kg
FRAZ. B / SECT. B	
2550 mm	45,9 kg
FRAZ. B / SECT. B	
3050 mm	54,9 kg
FRAZ. B / SECT. B	
4050 mm	72,9 kg
FRAZ. B / SECT. B	

3206

Mat = 42CrMo4
bonificato / tempered
Max T/m = 60
α = 30°

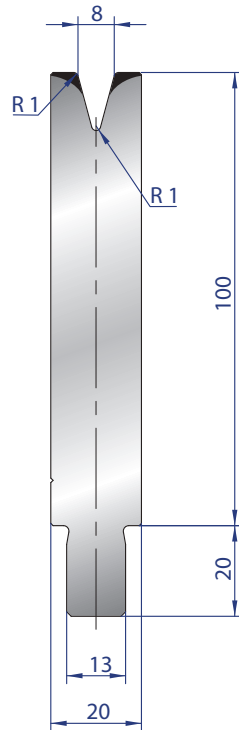

25-30	
35-40 mm	0,6 kg
45-50	
100 mm	1,7 kg
200 mm	3,4 kg
300 mm	5,1 kg
500 mm	8,6 kg
550 mm	9,5 kg
FRAZ. B / SECT. B	
1050 mm	17,8 kg
FRAZ. B / SECT. B	
1250 mm	21,2 kg
FRAZ. B / SECT. B	
2050 mm	34,8 kg
FRAZ. B / SECT. B	
2550 mm	43,3 kg
FRAZ. B / SECT. B	
3050 mm	51,8 kg
FRAZ. B / SECT. B	
4050 mm	68,8 kg
FRAZ. B / SECT. B	

3207

Mat = 42CrMo4
bonificato / tempered
Max T/m = 50
α = 30°

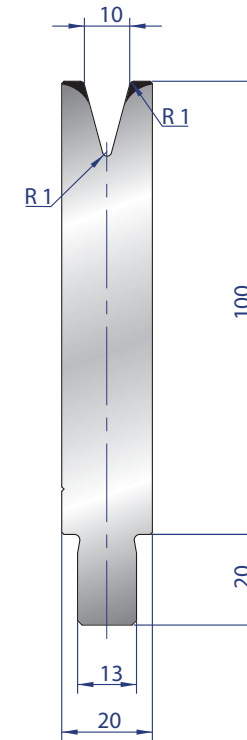

25-30	
35-40 mm	0,6 kg
45-50	
100 mm	1,7 kg
200 mm	3,4 kg
300 mm	5,1 kg
500 mm	8,6 kg
550 mm	9,5 kg
FRAZ. B / SECT. B	
1050 mm	17,8 kg
FRAZ. B / SECT. B	
1250 mm	21,2 kg
FRAZ. B / SECT. B	
2050 mm	34,8 kg
FRAZ. B / SECT. B	
2550 mm	43,3 kg
FRAZ. B / SECT. B	
3050 mm	51,8 kg
FRAZ. B / SECT. B	
4050 mm	68,8 kg
FRAZ. B / SECT. B	

3208

Mat = 42CrMo4
bonificato / tempered
Max T/m = 50
α = 30°



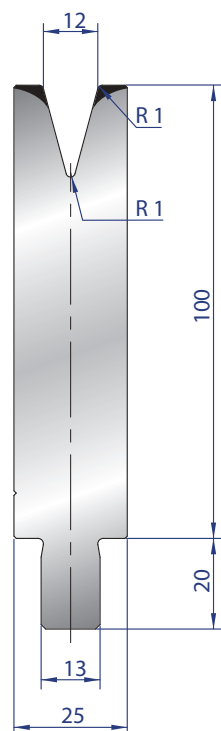

25-30	
35-40 mm	0,8 kg
45-50	
100 mm	2,0 kg
200 mm	4,1 kg
300 mm	6,2 kg
500 mm	10,2 kg
550 mm	11,3 kg
FRAZ. / SECT.	
1050 mm	21,0 kg
FRAZ. B / SECT. B	
1250 mm	25,0 kg
FRAZ. B / SECT. B	
2050 mm	41,0 kg
FRAZ. B / SECT. B	
2550 mm	51,0 kg
FRAZ. B / SECT. B	
3050 mm	61,0 kg
FRAZ. B / SECT. B	
4050 mm	81,0 kg
FRAZ. B / SECT. B	

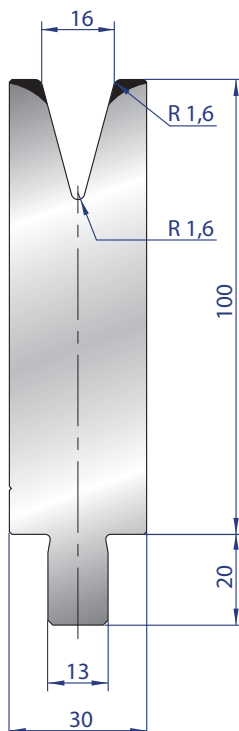

25-30	
35-40 mm	0,9 kg
45-50	
100 mm	2,4 kg
200 mm	4,8 kg
300 mm	7,2 kg
500 mm	11,8 kg
550 mm	13,0 kg
FRAZ. / SECT.	
1050 mm	25,2 kg
FRAZ. B / SECT. B	
1250 mm	30,0 kg
FRAZ. B / SECT. B	
2050 mm	49,2 kg
FRAZ. B / SECT. B	
2550 mm	63,7 kg
FRAZ. B / SECT. B	
3050 mm	73,2 kg
FRAZ. B / SECT. B	
4050 mm	97,2 kg
FRAZ. B / SECT. B	

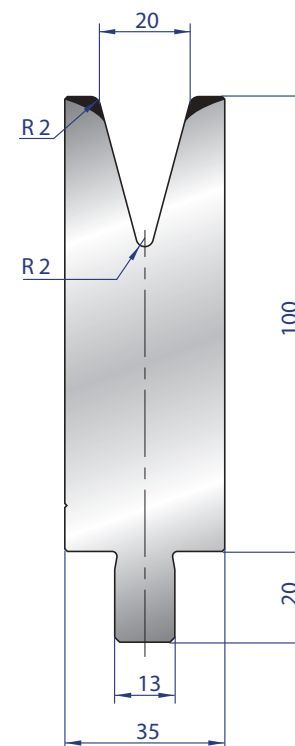

25-30	
35-40 mm	1,0 kg
45-50	
100 mm	2,6 kg
200 mm	5,2 kg
300 mm	7,8 kg
500 mm	13,0 kg
550 mm	13,0 kg
FRAZ. / SECT.	
1050 mm	27,3 kg
FRAZ. B / SECT. B	
1250 mm	32,5 kg
FRAZ. B / SECT. B	
2050 mm	53,3 kg
FRAZ. B / SECT. B	
2550 mm	66,3 kg
FRAZ. B / SECT. B	
3050 mm	79,3 kg
FRAZ. B / SECT. B	
4050 mm	105,3 kg
FRAZ. B / SECT. B	

3209

Mat = 42CrMo4
bonificato / tempered
Max T/m = 56
α = 30°

3210

Mat = 42CrMo4
bonificato / tempered
Max T/m = 68
α = 30°

3211

Mat = 42CrMo4
bonificato / tempered
Max T/m = 50
α = 30°

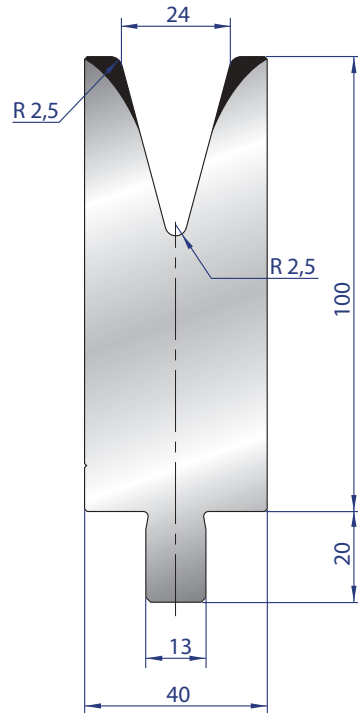

25-30		
35-40 mm	1,1 kg	
45-50		
100 mm	2,9 kg	
200 mm	5,8 kg	
300 mm	8,7 kg	
500 mm	14,5 kg	
550 mm	16,0 kg	
1050 mm	30,4 kg	FRAZ. B / SECT. B
1250 mm	36,2 kg	FRAZ. B / SECT. B
2050 mm	59,4 kg	FRAZ. B / SECT. B
2550 mm	73,9 kg	FRAZ. B / SECT. B
3050 mm	88,4 kg	FRAZ. B / SECT. B
4050 mm	117,4 kg	FRAZ. B / SECT. B

3212

Mat = 42CrMo4
bonificato / tempered
Max T/m = 55
α = 30°

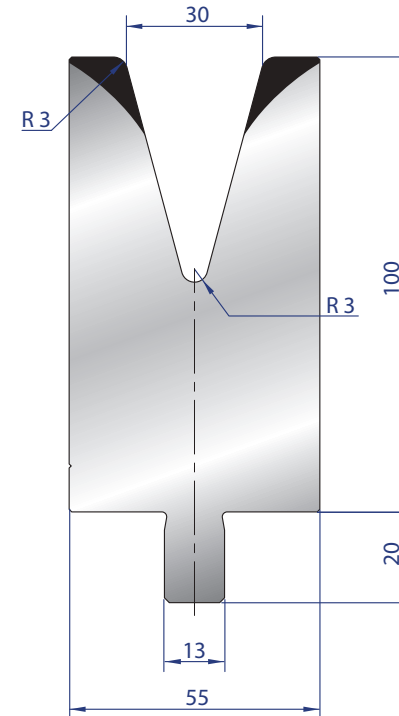

25-30		
35-40 mm	1,5 kg	
45-50		
100 mm	3,8 kg	
200 mm	7,6 kg	
300 mm	11,4 kg	
500 mm	19,0 kg	
550 mm	20,9 kg	FRAZ. B / SECT. B
1050 mm	39,9 kg	FRAZ. B / SECT. B
1250 mm	47,5 kg	FRAZ. B / SECT. B
2050 mm	77,9 kg	FRAZ. B / SECT. B
2550 mm	96,9 kg	FRAZ. B / SECT. B
3050 mm	115,9 kg	FRAZ. B / SECT. B
4050 mm	153,9 kg	FRAZ. B / SECT. B

3213

Mat = 42CrMo4
bonificato / tempered
Max T/m = 85
α = 30°



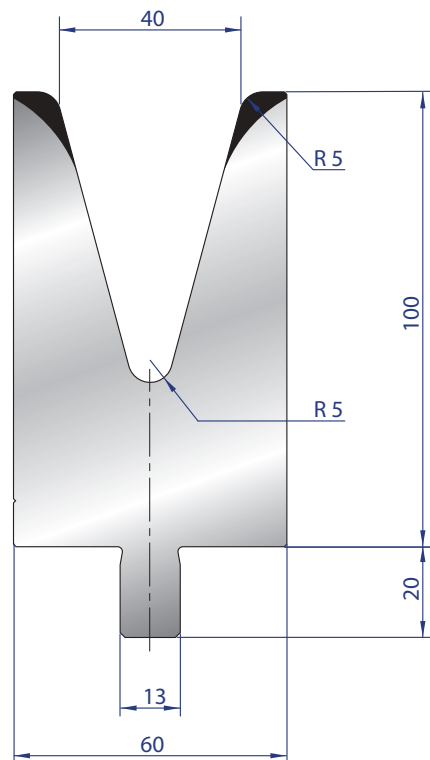

25-30	1,5 kg
35-40	
45-50	
100 mm	3,7 kg
200 mm	7,4 kg
300 mm	11,1 kg
500 mm	18,5 kg
550 mm FRAZ. B / SECT. B	20,4 kg
1050 mm FRAZ. B / SECT. B	38,8 kg
1250 mm FRAZ. B / SECT. B	46,2 kg
2050 mm FRAZ. B / SECT. B	75,8 kg
2550 mm FRAZ. B / SECT. B	94,3 kg
3050 mm FRAZ. B / SECT. B	112,8 kg
4050 mm FRAZ. B / SECT. B	149,8 kg

3214

Mat = 42CrMo4
bonificato / tempered
Max T/m = 73
α = 30°

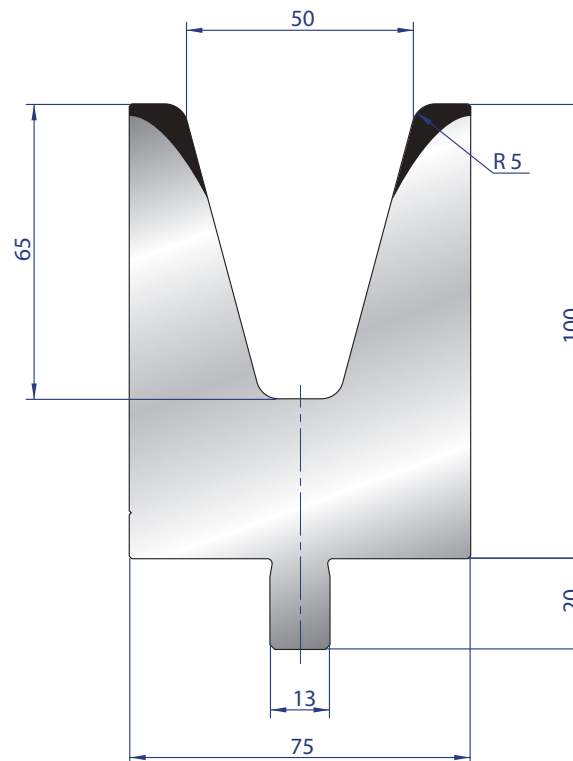

25-30	1,8 kg
35-40	
45-50	
100 mm	4,6 kg
200 mm	9,2 kg
300 mm	13,8 kg
500 mm	23,0 kg
550 mm FRAZ. B / SECT. B	25,3 kg
1050 mm FRAZ. B / SECT. B	48,3 kg
1250 mm FRAZ. B / SECT. B	57,5 kg
2050 mm FRAZ. B / SECT. B	94,3 kg
2550 mm FRAZ. B / SECT. B	117,3 kg
3050 mm FRAZ. B / SECT. B	140,3 kg
4050 mm FRAZ. B / SECT. B	186,3 kg

3235

Mat = 42CrMo4
bonificato / tempered
Max T/m = 100
α = 30°

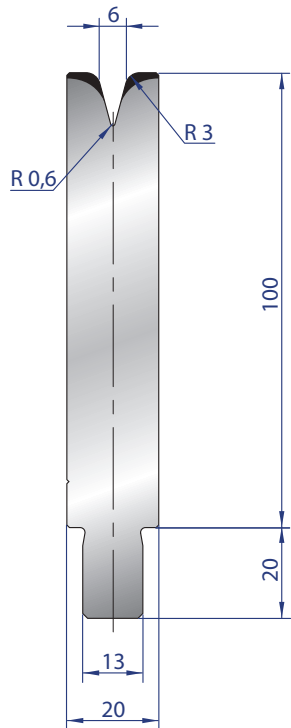

25-30	
35-40 mm	0,6 kg
45-50	
100 mm	1,8 kg
200 mm	3,6 kg
300 mm	5,4 kg
500 mm	8,7 kg
550 mm	9,6 kg
FRAZ. / SECT.	
1050 mm	18,9 kg
FRAZ. B / SECT. B	
1250 mm	22,5 kg
FRAZ. B / SECT. B	
2050 mm	36,9 kg
FRAZ. B / SECT. B	
2550 mm	45,9 kg
FRAZ. B / SECT. B	
3050 mm	54,9 kg
FRAZ. B / SECT. B	
4050 mm	72,9 kg
FRAZ. B / SECT. B	

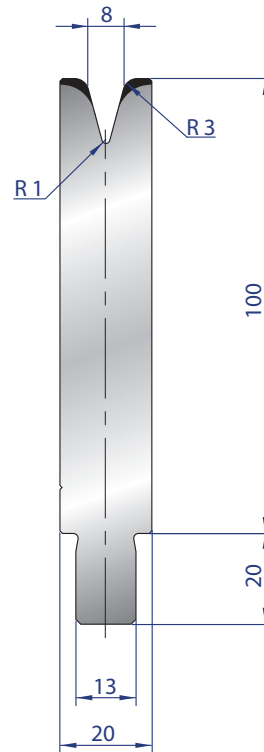

25-30	
35-40 mm	0,6 kg
45-50	
100 mm	1,7 kg
200 mm	3,4 kg
300 mm	5,1 kg
500 mm	8,6 kg
550 mm	9,5 kg
FRAZ. / SECT.	
1050 mm	17,8 kg
FRAZ. B / SECT. B	
1250 mm	21,2 kg
FRAZ. B / SECT. B	
2050 mm	34,8 kg
FRAZ. B / SECT. B	
2550 mm	43,3 kg
FRAZ. B / SECT. B	
3050 mm	51,8 kg
FRAZ. B / SECT. B	
4050 mm	68,8 kg
FRAZ. B / SECT. B	

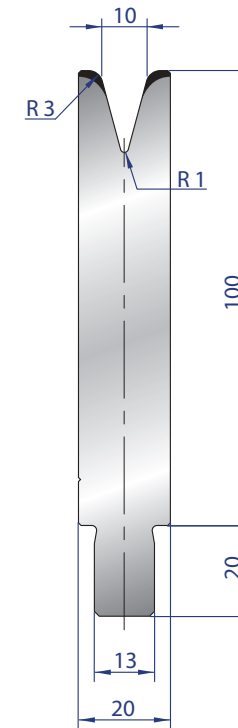

25-30	
35-40 mm	0,6 kg
45-50	
100 mm	1,7 kg
200 mm	3,4 kg
300 mm	5,1 kg
500 mm	8,6 kg
550 mm	9,5 kg
FRAZ. / SECT.	
1050 mm	17,8 kg
FRAZ. B / SECT. B	
1250 mm	21,2 kg
FRAZ. B / SECT. B	
2050 mm	34,8 kg
FRAZ. B / SECT. B	
2550 mm	43,3 kg
FRAZ. B / SECT. B	
3050 mm	51,8 kg
FRAZ. B / SECT. B	
4050 mm	68,8 kg
FRAZ. B / SECT. B	

3236

Mat = 42CrMo4
bonificato / tempered
Max T/m = 45
α = 30°

3237

Mat = 42CrMo4
bonificato / tempered
Max T/m = 40
α = 30°

3238

Mat = 42CrMo4
bonificato / tempered
Max T/m = 30
α = 30°



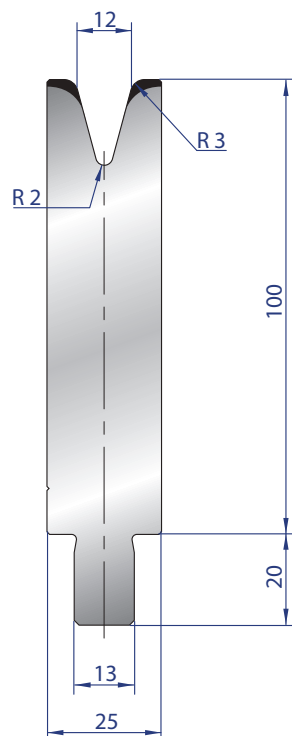

25-30	
35-40 mm	0,8 kg
45-50	
100 mm	2,0 kg
200 mm	4,1 kg
300 mm	6,2 kg
500 mm	10,2 kg
550 mm	11,3 kg
FRAZ. / SECT.	
1050 mm	21,0 kg
FRAZ. B / SECT. B	
1250 mm	25,0 kg
FRAZ. B / SECT. B	
2050 mm	41,0 kg
FRAZ. B / SECT. B	
2550 mm	51,0 kg
FRAZ. B / SECT. B	
3050 mm	61,0 kg
FRAZ. B / SECT. B	
4050 mm	81,0 kg
FRAZ. B / SECT. B	

3239

Mat = 42CrMo4
bonificato / tempered
Max T/m = 40
α = 30°

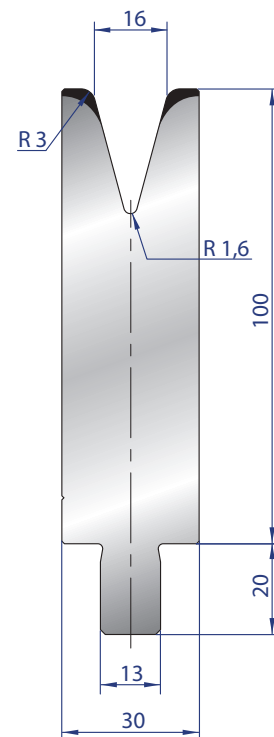

25-30	
35-40 mm	0,9 kg
45-50	
100 mm	2,4 kg
200 mm	4,8 kg
300 mm	7,2 kg
500 mm	11,8 kg
550 mm	13,0 kg
FRAZ. / SECT.	
1050 mm	25,2 kg
FRAZ. B / SECT. B	
1250 mm	30,0 kg
FRAZ. B / SECT. B	
2050 mm	49,2 kg
FRAZ. B / SECT. B	
2550 mm	63,7 kg
FRAZ. B / SECT. B	
3050 mm	73,2 kg
FRAZ. B / SECT. B	
4050 mm	97,2 kg
FRAZ. B / SECT. B	

3240

Mat = 42CrMo4
bonificato / tempered
Max T/m = 40
α = 30°

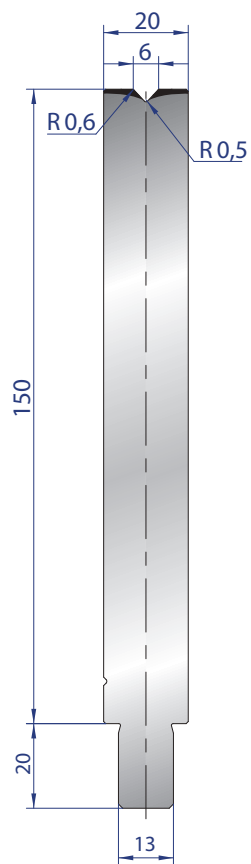

25-30	1,0 kg
35-40 mm	
45-50	
100 mm	2,6 kg
200 mm	5,2 kg
300 mm	7,8 kg
500 mm	13,0 kg
550 mm	13,0 kg
FRAZ. / SECT.	
1050 mm	27,3 kg
FRAZ. B / SECT. B	
1250 mm	32,5 kg
FRAZ. B / SECT. B	
2050 mm	53,3 kg
FRAZ. B / SECT. B	
2550 mm	66,3 kg
FRAZ. B / SECT. B	
3050 mm	79,3 kg
FRAZ. B / SECT. B	
4050 mm	105,3 kg
FRAZ. B / SECT. B	

3143

Mat = C45
Max T/m = 100
 $\alpha = 86^\circ$

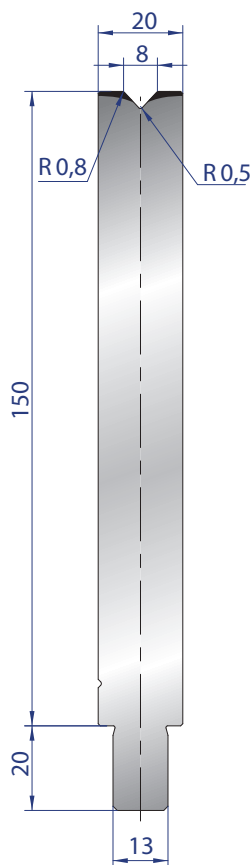

25-30	1,0 kg
35-40 mm	
45-50	
100 mm	2,6 kg
200 mm	5,2 kg
300 mm	7,8 kg
500 mm	13,0 kg
550 mm	13,0 kg
FRAZ. / SECT.	
1050 mm	27,3 kg
FRAZ. B / SECT. B	
1250 mm	32,5 kg
FRAZ. B / SECT. B	
2050 mm	53,3 kg
FRAZ. B / SECT. B	
2550 mm	66,3 kg
FRAZ. B / SECT. B	
3050 mm	79,3 kg
FRAZ. B / SECT. B	
4050 mm	105,3 kg
FRAZ. B / SECT. B	

3144

Mat = C45
Max T/m = 100
 $\alpha = 86^\circ$

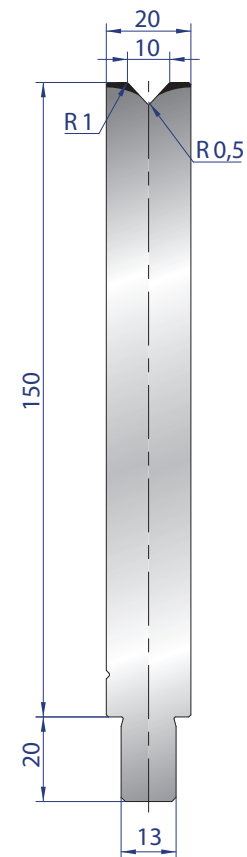

25-30	1,0 kg
35-40 mm	
45-50	
100 mm	2,6 kg
200 mm	5,2 kg
300 mm	7,8 kg
500 mm	13,0 kg
550 mm	13,0 kg
FRAZ. / SECT.	
1050 mm	27,3 kg
FRAZ. B / SECT. B	
1250 mm	32,5 kg
FRAZ. B / SECT. B	
2050 mm	53,3 kg
FRAZ. B / SECT. B	
2550 mm	66,3 kg
FRAZ. B / SECT. B	
3050 mm	79,3 kg
FRAZ. B / SECT. B	
4050 mm	105,3 kg
FRAZ. B / SECT. B	

3145

Mat = C45
Max T/m = 100
 $\alpha = 86^\circ$



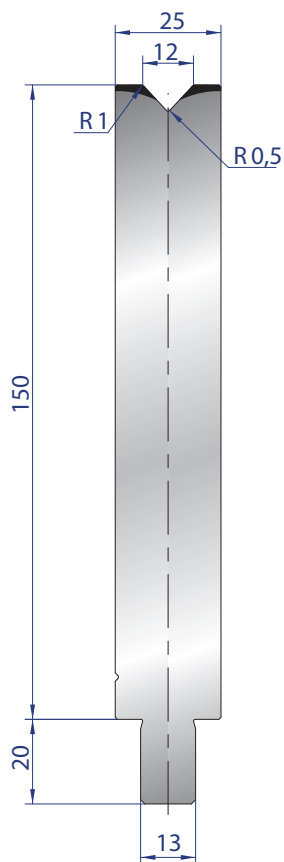

25-30	1,3 kg
35-40 mm	
45-50	
100 mm	3,2 kg
200 mm	6,4 kg
300 mm	9,6 kg
500 mm	16,0 kg
550 mm	16,0 kg
<small>FRAZ. / SECT.</small>	
1050 mm	33,6 kg
<small>FRAZ. B / SECT. B</small>	
1250 mm	40,0 kg
<small>FRAZ. B / SECT. B</small>	
2050 mm	65,6 kg
<small>FRAZ. B / SECT. B</small>	
2550 mm	81,6 kg
<small>FRAZ. B / SECT. B</small>	
3050 mm	97,6 kg
<small>FRAZ. B / SECT. B</small>	
4050 mm	129,6 kg
<small>FRAZ. B / SECT. B</small>	

3146

Mat = C45
Max T/m = 100
 $\alpha = 86^\circ$

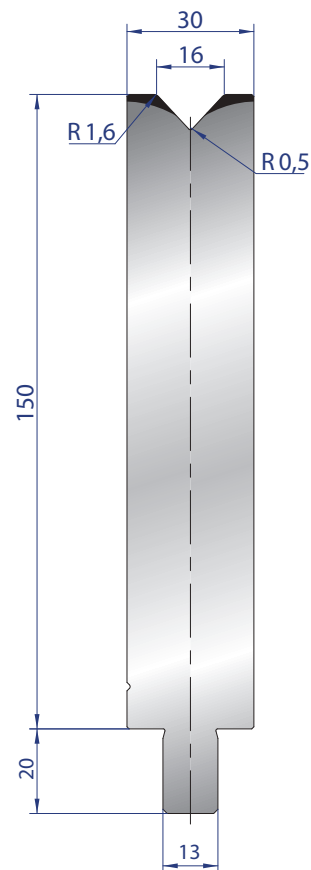

25-30	1,4 kg
35-40 mm	
45-50	
100 mm	3,6 kg
200 mm	7,2 kg
300 mm	10,8 kg
500 mm	18,0 kg
550 mm	18,0 kg
<small>FRAZ. / SECT.</small>	
1050 mm	37,8 kg
<small>FRAZ. B / SECT. B</small>	
1250 mm	45,0 kg
<small>FRAZ. B / SECT. B</small>	
2050 mm	73,8 kg
<small>FRAZ. B / SECT. B</small>	
2550 mm	91,8 kg
<small>FRAZ. B / SECT. B</small>	
3050 mm	109,8 kg
<small>FRAZ. B / SECT. B</small>	
4050 mm	145,8 kg
<small>FRAZ. B / SECT. B</small>	

3147

Mat = C45
Max T/m = 100
 $\alpha = 86^\circ$

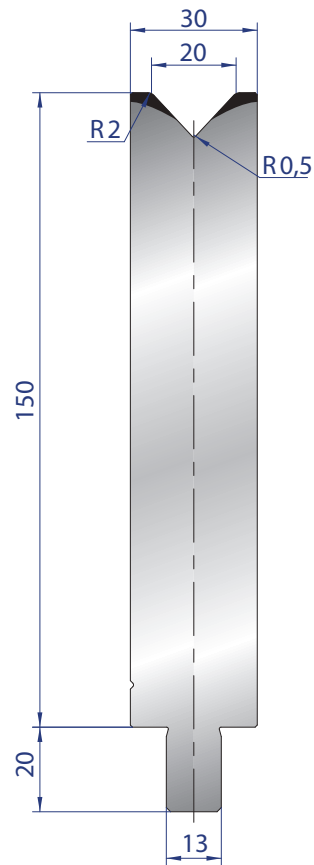

25-30	1,4 kg
35-40 mm	
45-50	
100 mm	3,6 kg
200 mm	7,2 kg
300 mm	10,8 kg
500 mm	18,0 kg
550 mm FRAZ. B / SECT. B	18,0 kg
1050 mm FRAZ. B / SECT. B	37,8 kg
1250 mm FRAZ. B / SECT. B	45,0 kg
2050 mm FRAZ. B / SECT. B	73,8 kg
2550 mm FRAZ. B / SECT. B	91,8 kg
3050 mm FRAZ. B / SECT. B	109,8 kg
4050 mm FRAZ. B / SECT. B	145,8 kg

3148

Mat = C45
Max T/m = 100
 $\alpha = 86^\circ$

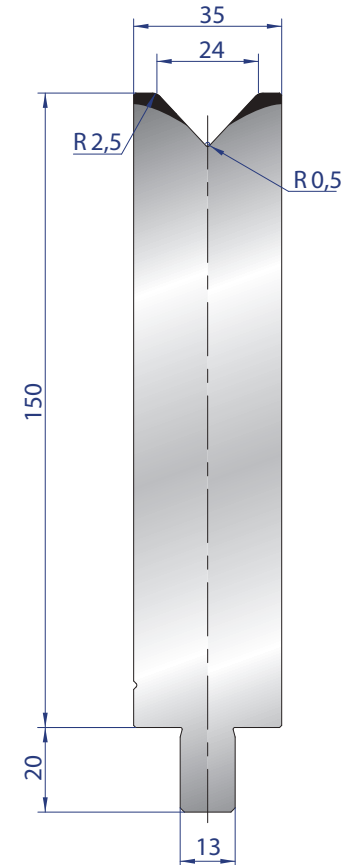

25-30	1,4 kg
35-40 mm	
45-50	
100 mm	3,6 kg
200 mm	7,2 kg
300 mm	10,8 kg
500 mm	18,0 kg
550 mm FRAZ. B / SECT. B	18,0 kg
1050 mm FRAZ. B / SECT. B	37,8 kg
1250 mm FRAZ. B / SECT. B	45,0 kg
2050 mm FRAZ. B / SECT. B	73,8 kg
2550 mm FRAZ. B / SECT. B	91,8 kg
3050 mm FRAZ. B / SECT. B	109,8 kg
4050 mm FRAZ. B / SECT. B	145,8 kg

3149

Mat = C45
Max T/m = 100
 $\alpha = 86^\circ$



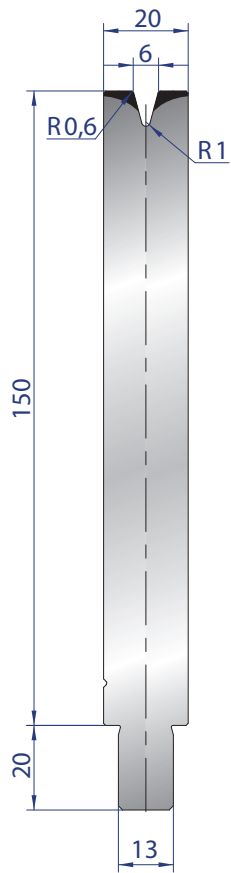

25-30	1,0 kg
35-40 mm	
45-50	
100 mm	2,6 kg
200 mm	5,2 kg
300 mm	7,8 kg
500 mm	13,0 kg
550 mm	13,0 kg
FRAZ. / SECT.	
1050 mm	27,3 kg
FRAZ. B / SECT. B	
1250 mm	32,5 kg
FRAZ. B / SECT. B	
2050 mm	53,3 kg
FRAZ. B / SECT. B	
2550 mm	66,3 kg
FRAZ. B / SECT. B	
3050 mm	79,3 kg
FRAZ. B / SECT. B	
4050 mm	105,3 kg
FRAZ. B / SECT. B	

3150

Mat = C45
Max T/m = 50
 $\alpha = 30^\circ$

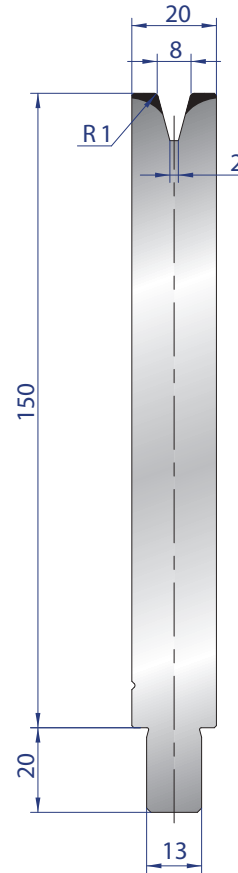

25-30	1,0 kg
35-40 mm	
45-50	
100 mm	2,6 kg
200 mm	5,2 kg
300 mm	7,8 kg
500 mm	13,0 kg
550 mm	13,0 kg
FRAZ. / SECT.	
1050 mm	27,3 kg
FRAZ. B / SECT. B	
1250 mm	32,5 kg
FRAZ. B / SECT. B	
2050 mm	53,3 kg
FRAZ. B / SECT. B	
2550 mm	66,3 kg
FRAZ. B / SECT. B	
3050 mm	79,3 kg
FRAZ. B / SECT. B	
4050 mm	105,3 kg
FRAZ. B / SECT. B	

3151

Mat = C45
Max T/m = 40
 $\alpha = 30^\circ$

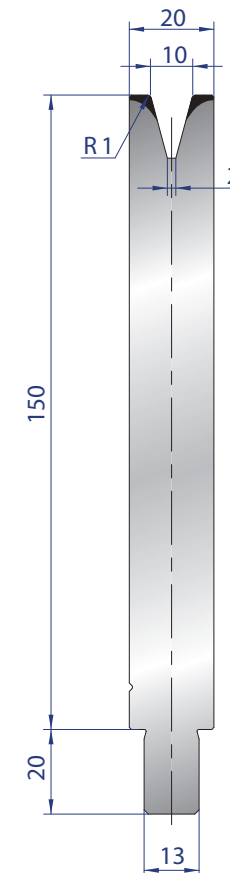

25-30	1,0 kg
35-40 mm	
45-50	
100 mm	2,6 kg
200 mm	5,2 kg
300 mm	7,8 kg
500 mm	13,0 kg
550 mm	13,0 kg
FRAZ. / SECT.	
1050 mm	27,3 kg
FRAZ. B / SECT. B	
1250 mm	32,5 kg
FRAZ. B / SECT. B	
2050 mm	53,3 kg
FRAZ. B / SECT. B	
2550 mm	66,3 kg
FRAZ. B / SECT. B	
3050 mm	79,3 kg
FRAZ. B / SECT. B	
4050 mm	105,3 kg
FRAZ. B / SECT. B	

3152

Mat = C45
Max T/m = 40
 $\alpha = 30^\circ$



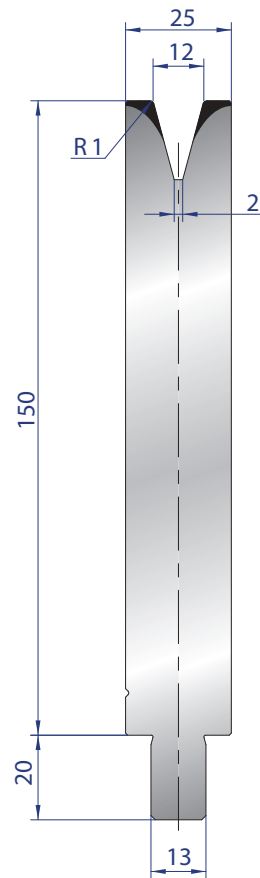

25-30	
35-40 mm	1,2 kg
45-50	
100 mm	3,0 kg
200 mm	6,0 kg
300 mm	9,0 kg
500 mm	15,0 kg
550 mm	15,0 kg
FRAZ. / SECT.	
1050 mm	31,5 kg
FRAZ. B / SECT. B	
1250 mm	37,5 kg
FRAZ. B / SECT. B	
2050 mm	61,5 kg
FRAZ. B / SECT. B	
2550 mm	76,5 kg
FRAZ. B / SECT. B	
3050 mm	91,5 kg
FRAZ. B / SECT. B	
4050 mm	121,5 kg
FRAZ. B / SECT. B	

3153

Mat = C45
Max T/m = 50
 $\alpha = 30^\circ$

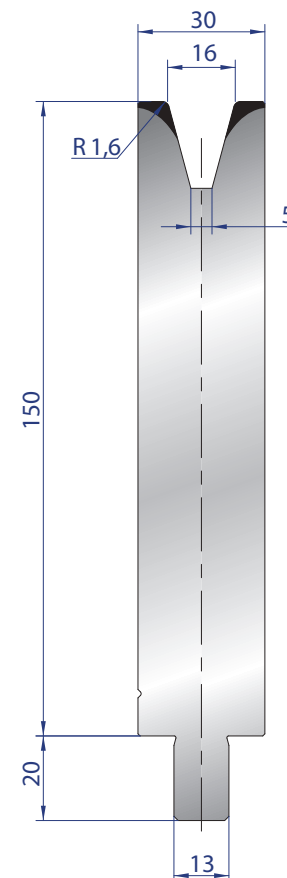

25-30	
35-40 mm	1,4 kg
45-50	
100 mm	3,6 kg
200 mm	7,2 kg
300 mm	10,8 kg
500 mm	18,0 kg
550 mm	18,0 kg
FRAZ. / SECT.	
1050 mm	37,8 kg
FRAZ. B / SECT. B	
1250 mm	45,0 kg
FRAZ. B / SECT. B	
2050 mm	73,8 kg
FRAZ. B / SECT. B	
2550 mm	91,8 kg
FRAZ. B / SECT. B	
3050 mm	109,8 kg
FRAZ. B / SECT. B	
4050 mm	145,8 kg
FRAZ. B / SECT. B	

3154

Mat = C45
Max T/m = 45
 $\alpha = 30^\circ$

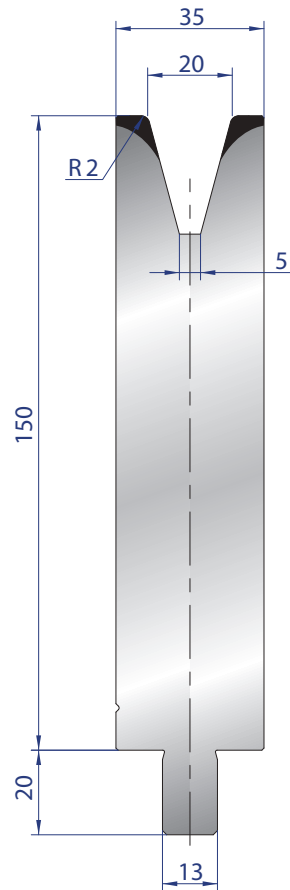

25-30		
35-40 mm	1,6 kg	
45-50		
100 mm	4,0 kg	
200 mm	8,0 kg	
300 mm	12,0 kg	
500 mm	20,0 kg	
550 mm	22,0 kg	
FRAZ. B / SECT. B		
1050 mm	42,0 kg	
FRAZ. B / SECT. B		
1250 mm	50,0 kg	
FRAZ. B / SECT. B		
2050 mm	82,0 kg	
FRAZ. B / SECT. B		
2550 mm	102,0 kg	
FRAZ. B / SECT. B		
3050 mm	122,0 kg	
FRAZ. B / SECT. B		
4050 mm	162,0 kg	
FRAZ. B / SECT. B		

3155

Mat = C45
Max T/m = 50
 $\alpha = 30^\circ$

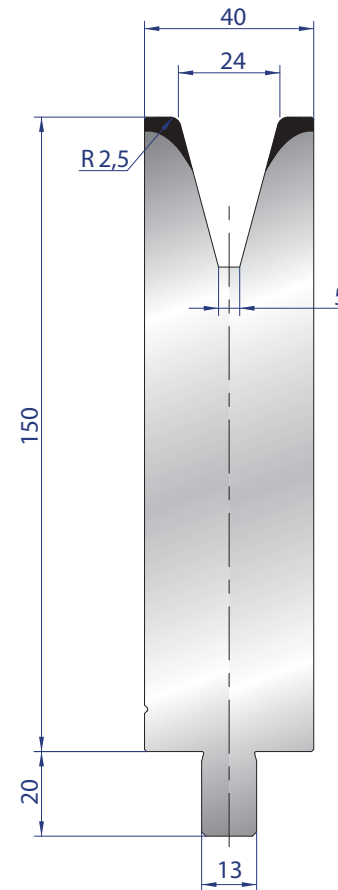

25-30		
35-40 mm	1,7 kg	
45-50		
100 mm	4,4 kg	
200 mm	8,8 kg	
300 mm	13,2 kg	
500 mm	22,0 kg	
550 mm	22,0 kg	
FRAZ. B / SECT. B		
1050 mm	46,2 kg	
FRAZ. B / SECT. B		
1250 mm	55,0 kg	
FRAZ. B / SECT. B		
2050 mm	90,2 kg	
FRAZ. B / SECT. B		
2550 mm	112,2 kg	
FRAZ. B / SECT. B		
3050 mm	134,2 kg	
FRAZ. B / SECT. B		
4050 mm	178,2 kg	
FRAZ. B / SECT. B		

3156

Mat = C45
Max T/m = 50
 $\alpha = 30^\circ$



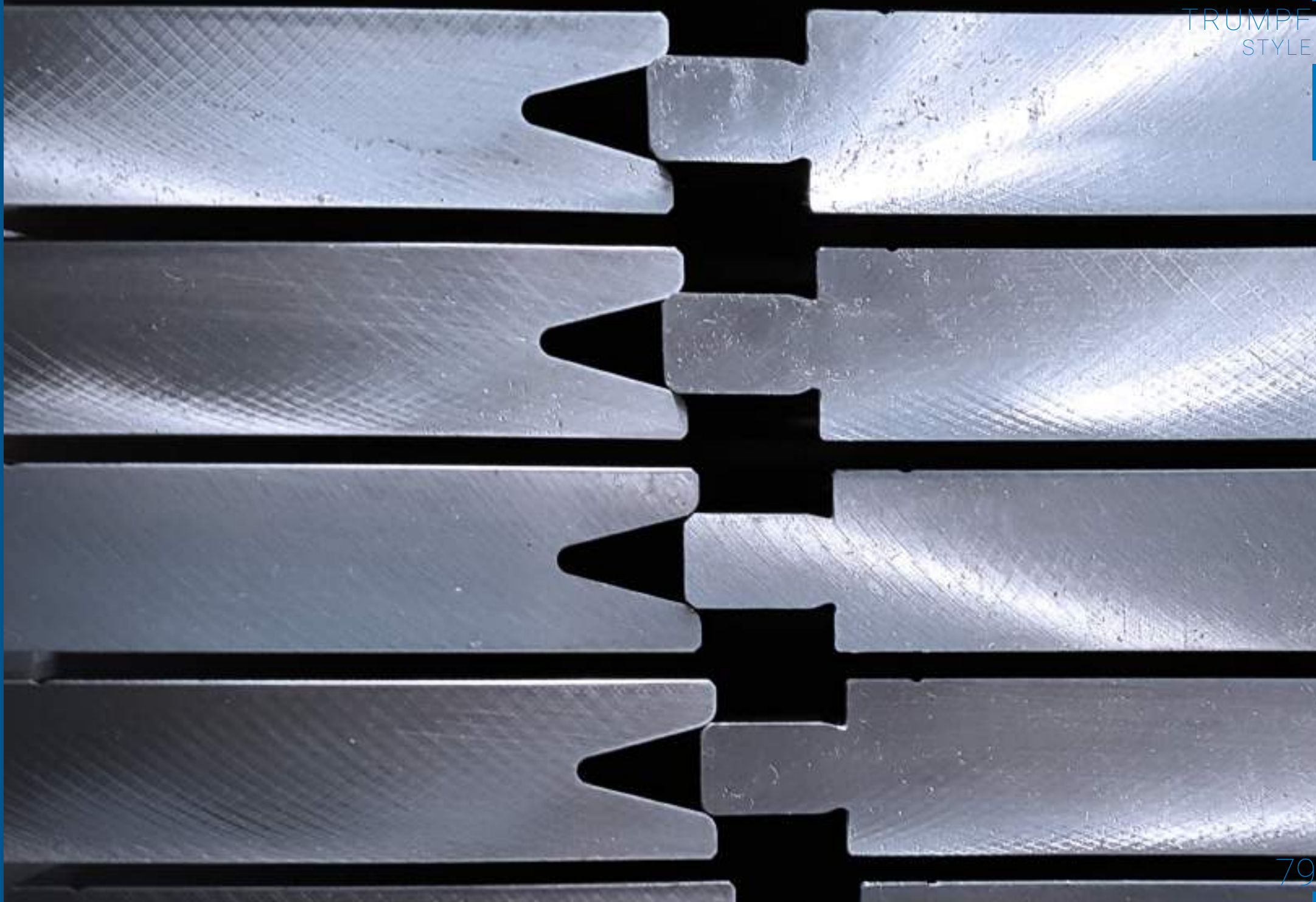

PIEGASCHIACCIA / FLATTENING HEMMING TOOLS

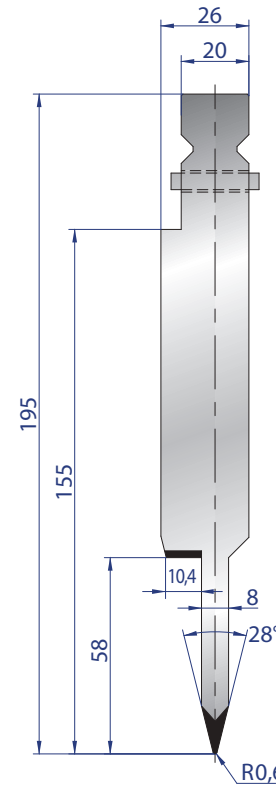

1249

Mat = C45
bonificato / tempered
Max T/m = 80

500 mm	14,0 kg
550 mm FRAZ. / SECT.	14,0 kg

Spessore:
Max 1,2 mm Ferro
Thickness:
Max 1,2 mm Mild steel

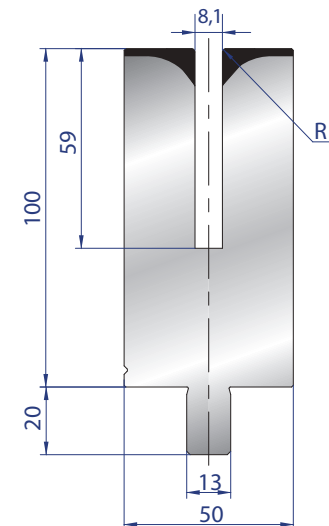

3157

Mat = C45
bonificato / tempered
Max T/m = 50

500 mm	21,0 kg
550 mm FRAZ. / SECT.	21,0 kg



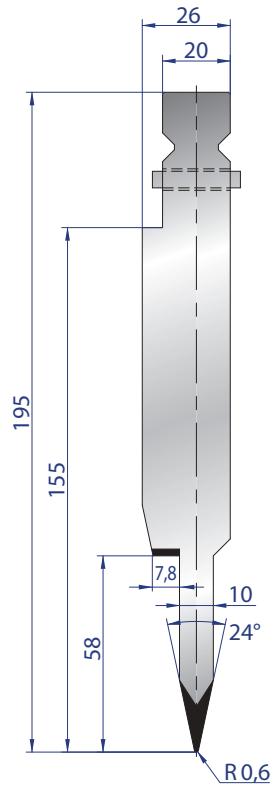

1250

Mat = C45
bonificato / tempered
Max T/m = 50

500 mm	14,0 kg
550 mm FRAZ. / SECT.	14,0 kg

Spessore:
Max 1,5 mm Ferro
Thickness:
Max 1,5 mm Mild steel

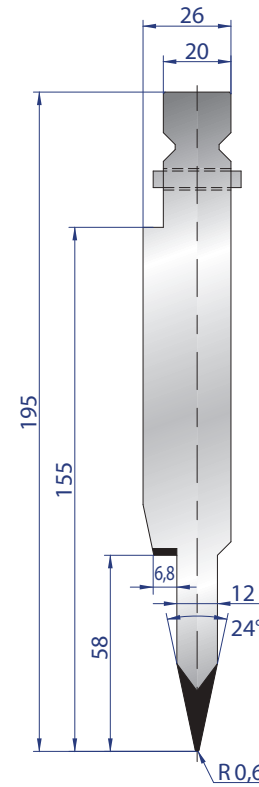

1251

Mat = C45
bonificato / tempered
Max T/m = 50

500 mm	15,0 kg
550 mm FRAZ. / SECT.	15,0 kg

Spessore:
Max 1,5 mm Ferro
Thickness:
Max 1,5 mm Mild steel

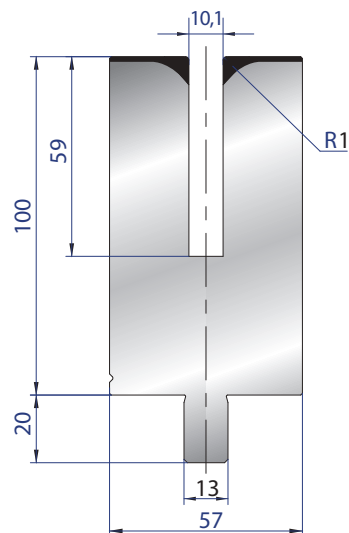

3174

Mat = C45
bonificato / tempered
Max T/m = 50

500 mm	20,0 kg
550 mm FRAZ. / SECT.	20,0 kg

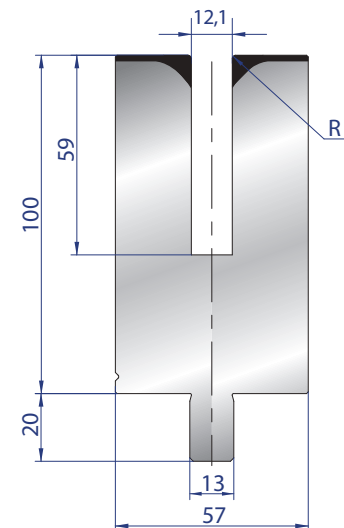

3175

Mat = C45
bonificato / tempered
Max T/m = 50

500 mm	20,0 kg
550 mm FRAZ. / SECT.	20,0 kg

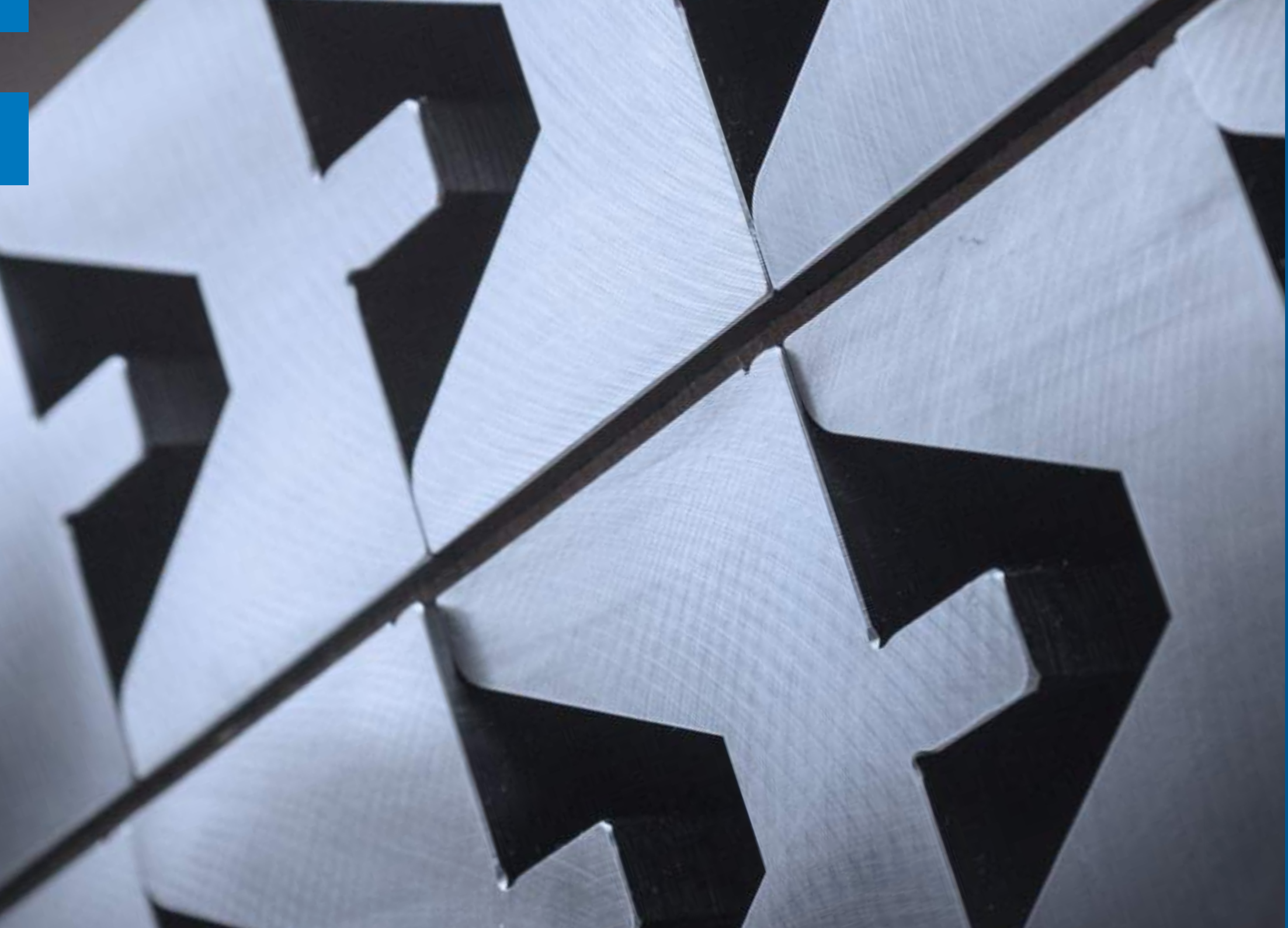



EUROSTAMP TOOLING
the Italian excellence



Eurostamp srl

sede di produzione / production site
uffici commerciali / sales office

Via A. Borotti 9/11
29121 Piacenza (Italy)
Tel. +39 0523 489 954
Tel. +39 0523 499 254
Fax +39 0523 400 490
info@eurostampsrl.it

www.eurostampsrl.it