

WILA STYLE



Press brake tooling and equipment

**UTENSILI E
ATTREZZATURE
PER PRESSE PIEGATRICI**

Eurostamp Tooling significa qualità, competenza e precisione. **Dal 1970 produciamo utensili e attrezzature per la piegatura straordinariamente precisi**, offrendo soluzioni di estrema qualità per tutti quei clienti che richiedono costantemente massimi livelli di performance e affidabilità.
“Eurostamp Tooling, the italian excellence”.

*Eurostamp Tooling means quality, competence, accuracy. **Since 1970** we have been manufacturing outstandingly accurate tooling and providing top quality solutions to all those customers who require the highest levels of performance and reliability.*

“Eurostamp Tooling, the italian excellence”



EUROSTAMP TOOLING
the Italian excellence



EUROSTAMP TOOLING

the Italian excellence

L'azienda è stata creata nel 1970 e, sin da allora, siamo orgogliosi di produrre e commercializzare **utensili e attrezzature per la piegatura** altamente performanti, affidabili e caratterizzati dai più elevati standard di qualità. Il nostro parco macchine utensili a elevata tecnologia e il magazzino con ampia disponibilità ci permettono di soddisfare ogni esigenza e richiesta speciale.

I nostri utensili sono realizzati con **acciai al carbonio e acciai speciali di provenienza italiana**, con tempra a induzione sulle parti usurabili che ne garantisce una **durezza di 55-60 HRC**. Offriamo un'ampia gamma di accessori per presse piegatrici: adattatori inferiori e superiori, sistemi di bloccaggio manuali e pneumatici.

Il nostro ufficio tecnico interno, inoltre, è in grado di studiare i progetti di piegatura personalizzati in modo tempestivo e accurato.

*The company was formed in 1970 and, since then, we have been proud to produce and market high performing, **reliable tools for bending**, which are characterised by the highest quality standards. Our highly-technological machine tool range and large warehouse facilities, allow us to meet every need and special requirement you may have*

*Our tools are made of **medium carbon steel and special Italian-sourced alloy steel**, with induction hardening on the parts subject to wear that guarantees **55-60 HRC hardness**.*

We provide a large range of accessories for press brakes: lower and upper adaptors, manual and pneumatic clamping systems. Our in-house technical office is also able to study fully customised bending projects in a timely and accurate manner.

CHI SIAMO

WHO WE ARE

LA NOSTRA FILOSOFIA

Eurostamp Tooling è un'azienda con cuore italiano e anima internazionale; abbiamo deciso di concentrarci e **specializzarci esclusivamente nella produzione e sviluppo degli utensili di piegatura**, settore in cui abbiamo sviluppato la **più alta tecnologia applicata a ciascuno dei processi interni**.

Il nostro reparto produttivo pone la massima attenzione alla **cura dei dettagli, alla precisione e all'accurato** controllo della qualità con una ispirazione artigianale: selezioniamo i migliori fornitori italiani di materia prima, e investiamo costantemente **in attrezzature di qualità** e in spazi di stoccaggio di ampio respiro.

Poniamo una fortissima attenzione alla formazione dello staff tecnico e produttivo ed investiamo costantemente in **ricerca e sviluppo perché crediamo fortemente che il modo migliore per soddisfare i nostri clienti sia il superamento delle loro aspettative con soluzioni innovative e un supporto pre e post vendita di elevato livello**. Il team commerciale lavora quotidianamente a fianco dello staff tecnico e produttivo per diffondere ovunque la nostra filosofia di marchio.

OUR PHILOSOPHY

*Eurostamp Tooling is an Italian company with an international soul, we decided to **focus only on manufacturing and engineering of tooling for press brakes**, so we invested all of **our resources on the state-of-art technologies applied to any of internal processes**.*

*Our production department put the highest care on every detail, on the maximum **accuracy and on the minute quality control**, according to a craftsman mood: we selected the best raw materials suppliers among the Italian market, beside we have been steadily investing on the **highest quality equipment** and in a precisely organised warehouse.*

*We put a strong attention to train our production and engineering staff and to invest on **research and development activities** because we believe that the best way to satisfy the customer demands is to overcome his expectations with innovative solutions and with a high level pre and post sales support.*

Our sales staff works daily beside the production and the engineering departments in order to spread worldwide our brand philosophy.



*Our staff are specialists who **follow every production phase from choosing** the best steel to the procedures for machining, hardening and grinding of each piece. We are using only 100% Italian quality steel for granting always **the best accuracy and the conformity with the highest standards specifications**.*

Gli specialisti che compongono il nostro staff **controllano ogni fase produttiva**, dalla scelta delle leghe e degli acciai grezzi, **alle procedure di fresatura**, tempra e rettifica di ogni pezzo. Usiamo acciaio al 100% italiano per garantire massima **precisione e caratteristiche meccaniche ad alto standard qualitativo**.

LE COMPETENZE OUR COMPETENCES

Calcolo della forza di piega in aria

Air bending force calculation

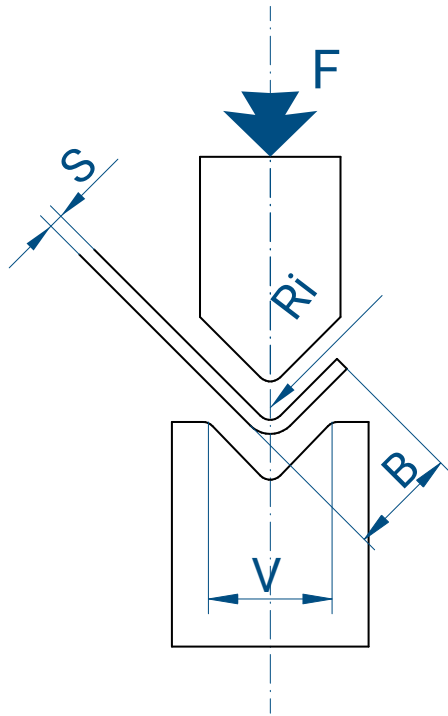

S	Spessore lamiera - mm Sheet metal thickness - mm	Ri	Raggio interno Inside radius
V	Larghezza del V V-opening	R	Alluminio 20-25 kg/mm ² Aluminium 20-25 kg/mm ²
F	Forza in T/m Force in T/m	R	Acciaio dolce 40-45 kg/mm ² Mild steel 40-45 kg/mm ²
B	Bordo minimo Shortest edge	R	Inox 65-70 kg/mm ² Stainless steel 65-70 kg/mm ²

$$F = \left| \frac{S^2 \times 2 \times R}{1.4 \times V} \right| = \dots \text{ ton/m}$$

Relazione tra spessore lamiera e larghezza V

Sheet metal thickness/V-shape width ratio

S	Spessore lamiera - mm Sheet metal thickness - mm	0,5-2,5	3-8	9-10	12 o più 12 or more
V	Larghezza del V "V" width	6 S	8 S	10 S	12 S



Tabella di piegatura in aria - Acciaio dolce / Air bending table - Mild Steel

S			mm	0,5	0,6	0,8	1	1,2	1,5	2	2,5	3	4	5	6	8	10	12	15	20	25	30	
6	4	1		3	4	7	11	16															
8	5,5	1,3			4	5	8	12	17														
10	7	1,6				4	7	10	15	27													
12	8,5	2					6	8	13	22	35												
16	11	2,6						6	9	17	26	38											
20	14	3,3							8	13	21	30	54										
25	17,5	4								11	17	24	42	67									
32	22	5									13	19	34	52	75								
40	28	6,5										15	27	42	60	107							
50	35	8											21	33	48	85	134						
63	45	10												26	38	68	105						
80	55	13													30	53	85	120					
100	71	16														43	67	96	150				
125	89	20															53	78	120	215			
160	113	26																60	95	170	265		
200	140	33																	75	135	210	300	
250	175	41																		108	170	240	
320	226	53																			85	130	190
V	B	Ri																					F

t/m

Tabella di piegatura in aria - Acciaio inox / Air bending table - Stainless Steel

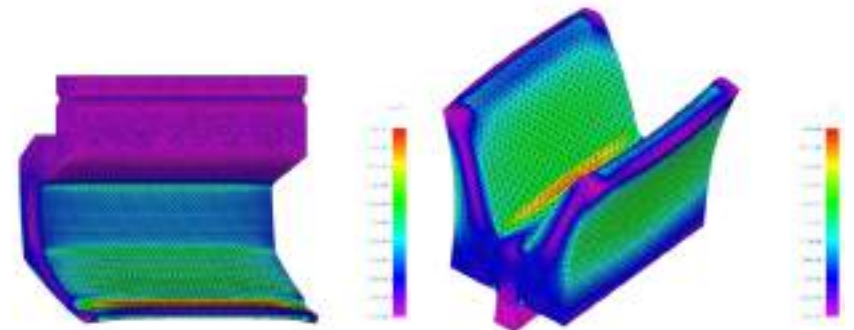
S			mm	0,5	0,6	0,8	1	1,2	1,5	2	2,5	3	4	5	6	8	10	12	15	20	25	30	
6	4	1		5	6	11	17	25															
8	5,5	1,3			6	8	12	19	26														
10	7	1,6				6	11	16	23	42													
12	8,5	2					9	12	20	34	54												
16	11	2,6						9	14	26	40	59											
20	14	3,3							12	20	33	47	84										
25	17,5	4								17	26	37	65	104									
32	22	5									20	30	53	81	117								
40	28	6,5										23	42	65	93	166							
50	35	8											33	51	75	132	208						
63	45	10												40	59	106	163						
80	55	13													47	82	132	187					
100	71	16														67	104	149	233				
125	89	20															82	121	187	334			
160	113	26																93	148	264	412		
200	140	33																	117	210	327	467	
250	175	41																		168	264	373	
320	226	53																			132	202	296
V	B	Ri																					F

t/m



EUROSTAMP TOOLING

the Italian excellence

Gli utensili superiori elencati in questa sezione possono essere installati sulle piegatrici:

Upper tooling listed on this section could be installed on the following press brakes:

Trumpf, LVD , Darley, Safan e su altre piegatrici equipaggiate con Sistema NSCL.

Trumpf, LVD, Darley, Safan, and on other press brakes equipped with System NSCL (New Standard Clamping).

Questi utensili possono essere installati che su altre piegatrici tramite adattatori superiori e inferiori.

These tooling are could also be installed on other press brakes by using the correct upper and lower adapters.

WILA

PUNZONI / PUNCHES	11	MATRICI / DIES	25
• Lunghezze standard /Standard lengths	11	• Lunghezze standard /Standard lengths	25
• Modifiche a richiesta / Modifications on request	13	• Modifiche a richiesta / Modifications on request	27
• Punzoni / Punches 86°.....	15-17	• Matrici 86°.....	29-39
• Punzoni / Punches 28°.....	19-23	• Matrici 30°.....	41-50

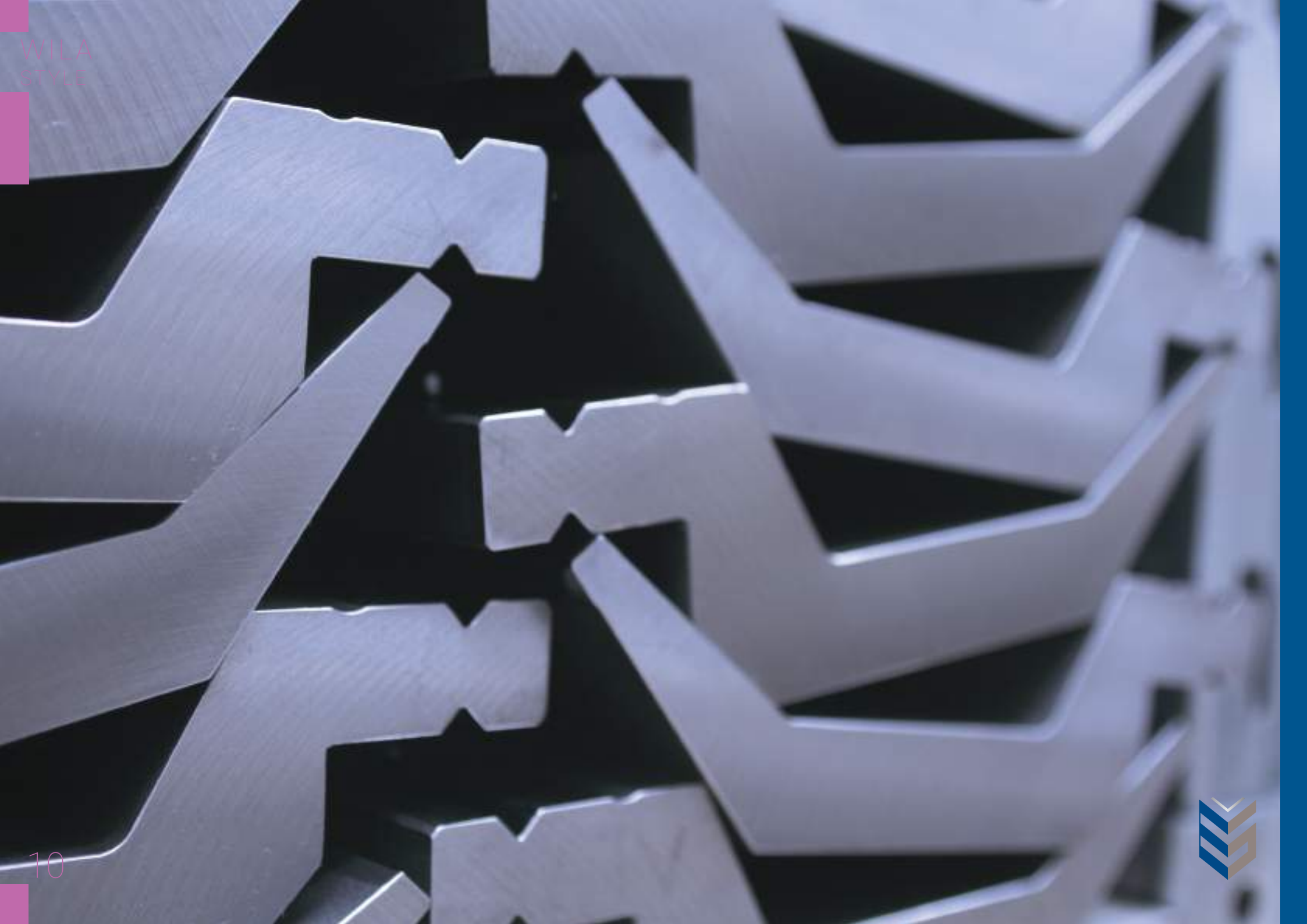

WILA
STYLE



LUNGHEZZE STANDARD
STANDARD LENGTHS

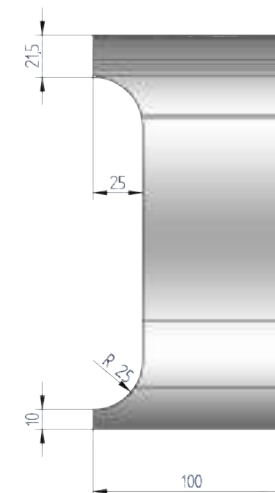
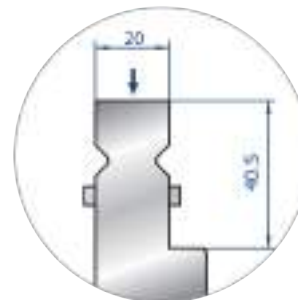
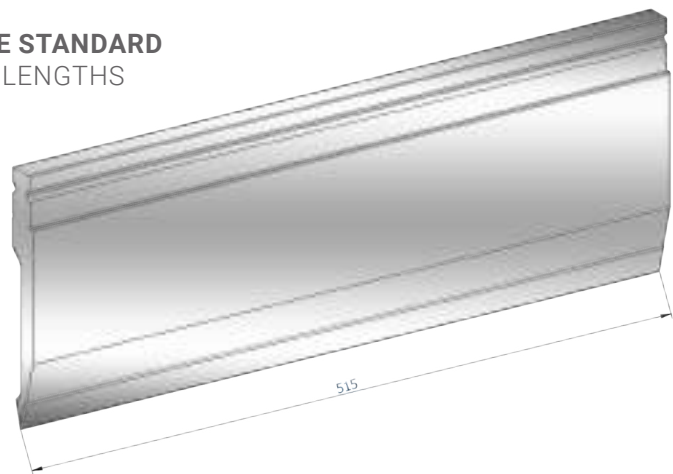

FRAZIONATURA STANDARD
STANDARD SEGMENTATION

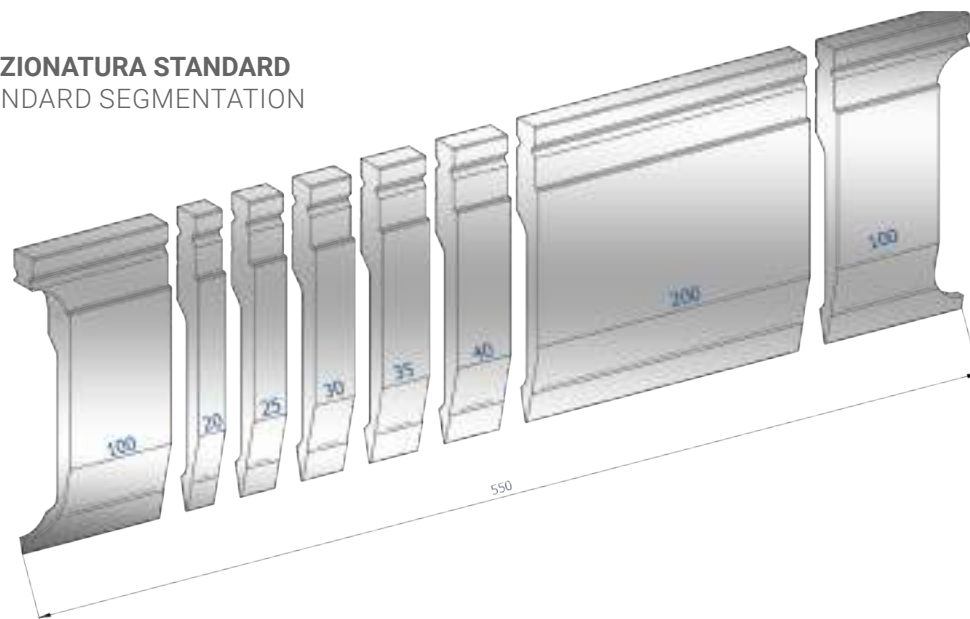

FRESATURA SCARPETTA
MILLED HORN



Il pulsante di sicurezza
viene montato standard
su tutti gli utensili con
peso fino a
12,5 Kg

The safety button is a
standard supply on all
tooling up to
12.5kg weigh



SCARPETTE SPECIALI
SPECIAL HORNS

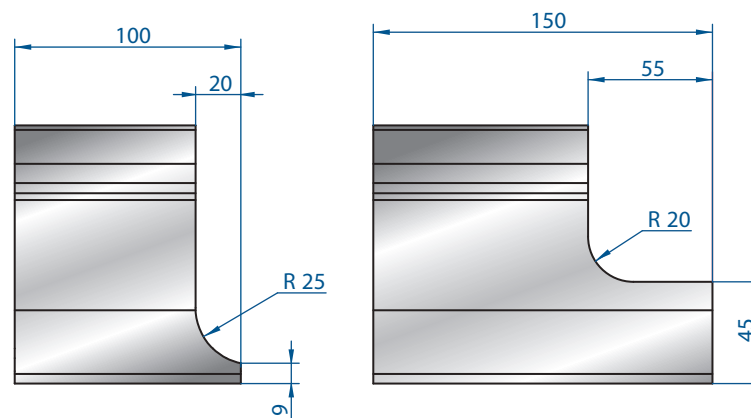

TAGLI A RICHIESTA
SPECIAL SEGMENTATION



MODIFICA RAGGIO
RADIUS MODIFICATION

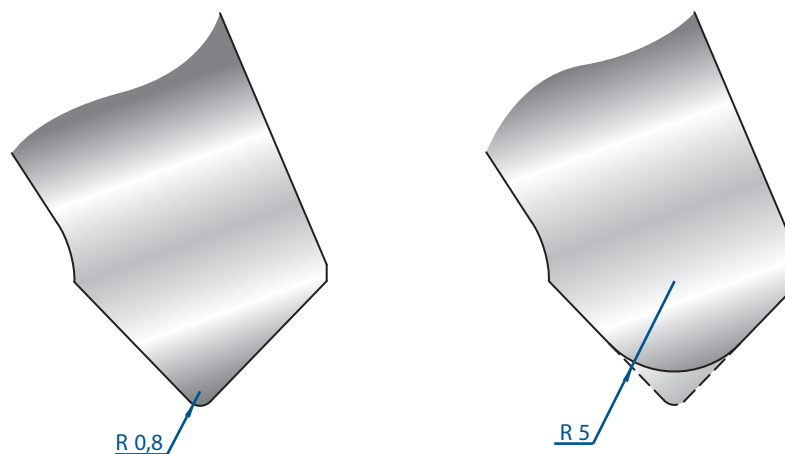



1323

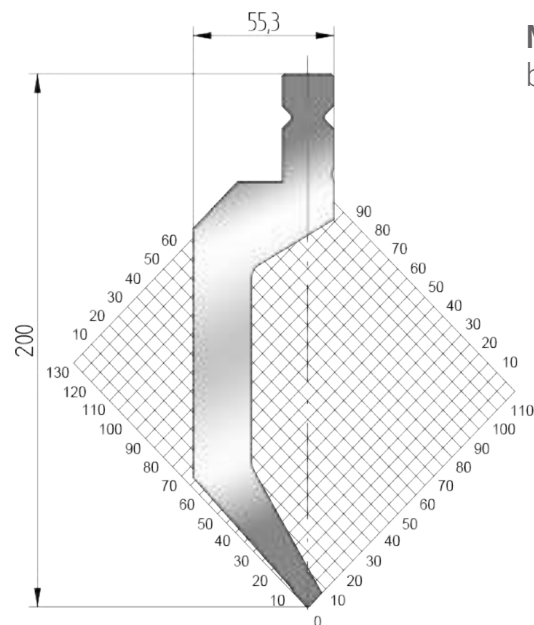

Mat = 42CrMo4
bonificato / tempered

H = 200.00

Max T/m = 65

α = 86°

R = 1

515 mm	19,1 kg
550 mm FRAZ. / SECT.	19 kg



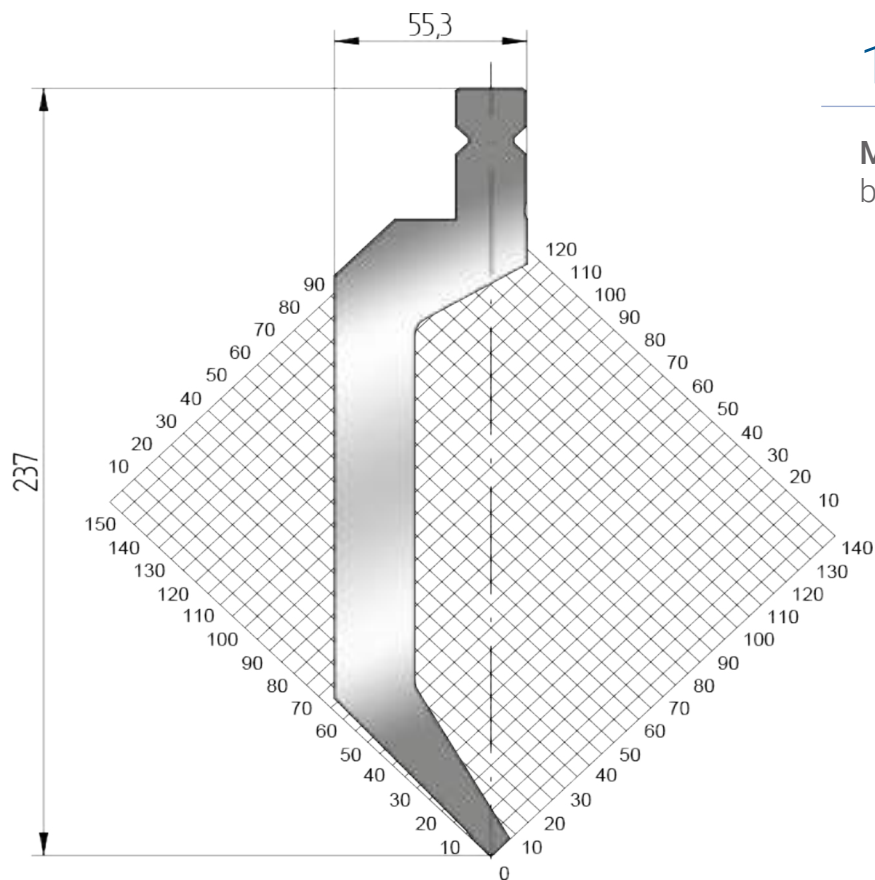

1324

Mat = 42CrMo4
bonificato / tempered

H = 237.00

Max T/m = 65

α = 86°

R = 1

515 mm	22,5 kg
550 mm FRAZ. / SECT.	22,3 kg



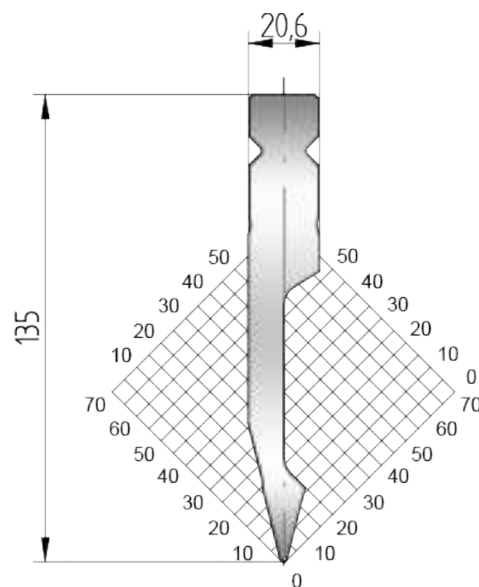

1325

Mat = 42CrMo4
 bonificato / tempered
H = 135.00
Max T/m = 100
 α = 28°
R = 1

515 mm	7,2 kg
550 mm FRAZ. / SECT.	7,3 kg



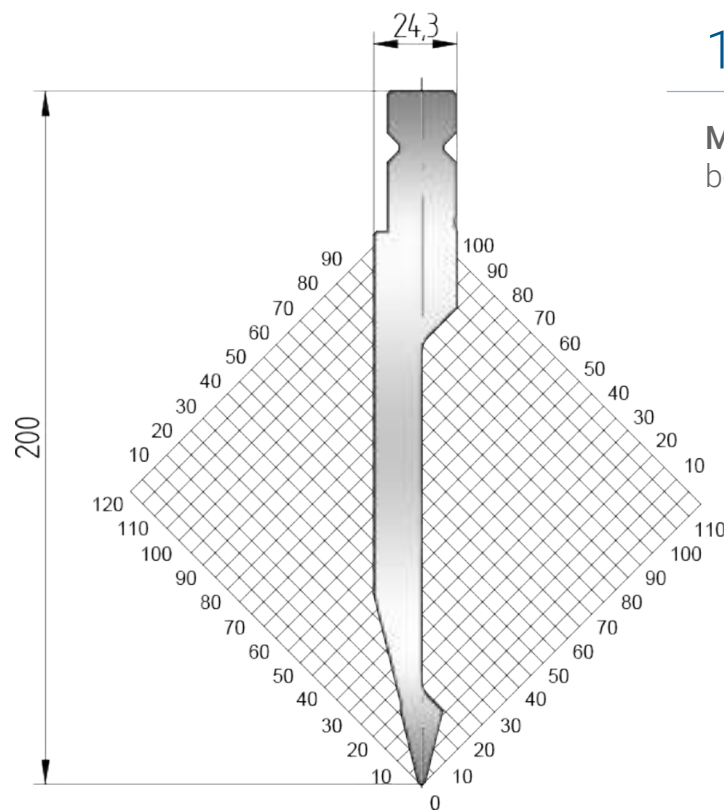

1326

Mat = 42CrMo4
bonificato / tempered

H = 200.00

Max T/m = 80

α = 28°

R = 1

515 mm	12,1 kg
550 mm FRAZ. / SECT.	12,1 kg



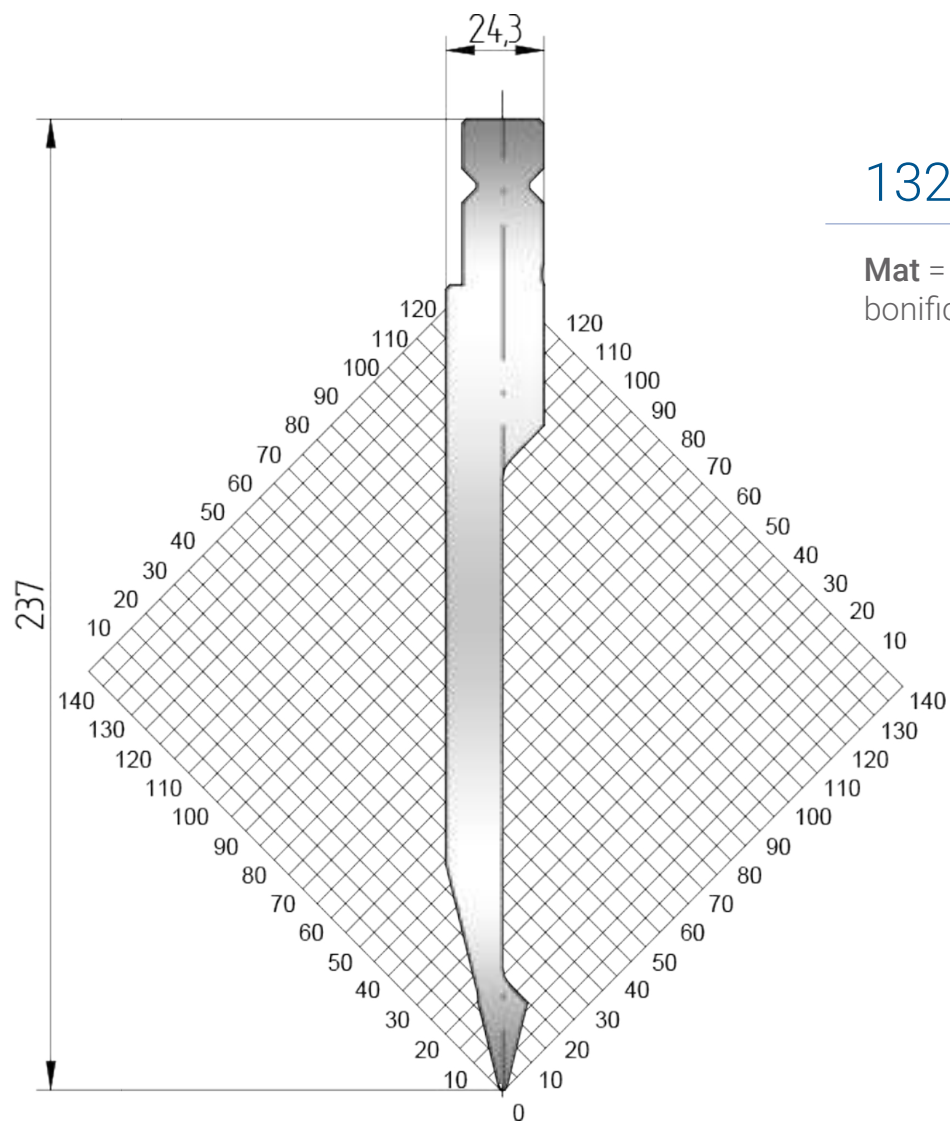

1327

Mat = 42CrMo4
 bonificato / tempered
H = 237.00
Max T/m = 80
 α = 28°
R = 1

515 mm	14,7 kg
550 mm FRAZ. / SECT.	14,7 kg



EUROSTAMP TOOLING

the Italian excellence

Gli utensili inferiori elencati in questa sezione possono essere installati sulle piegatrici:

Lower tooling listed on this section could be installed on the following press brakes:

Trumpf, Darley, Safan, Beyeler/Bystronic, SMD e su altre piegatrici equipaggiate con Sistema NSCR / OB

Trumpf, Darley, Safan, Beyeler/Bystronic, SMD and on other press brakes equipped with System NSCR / OB.

Questi utensili possono essere installati che su altre piegatrici tramite adattatori superiori e inferiori

These tooling are could also be installed on other press brakes by using the correct upper and lower adapters

FRAZIONATURA STANDARD
STANDARD SEGMENTATION

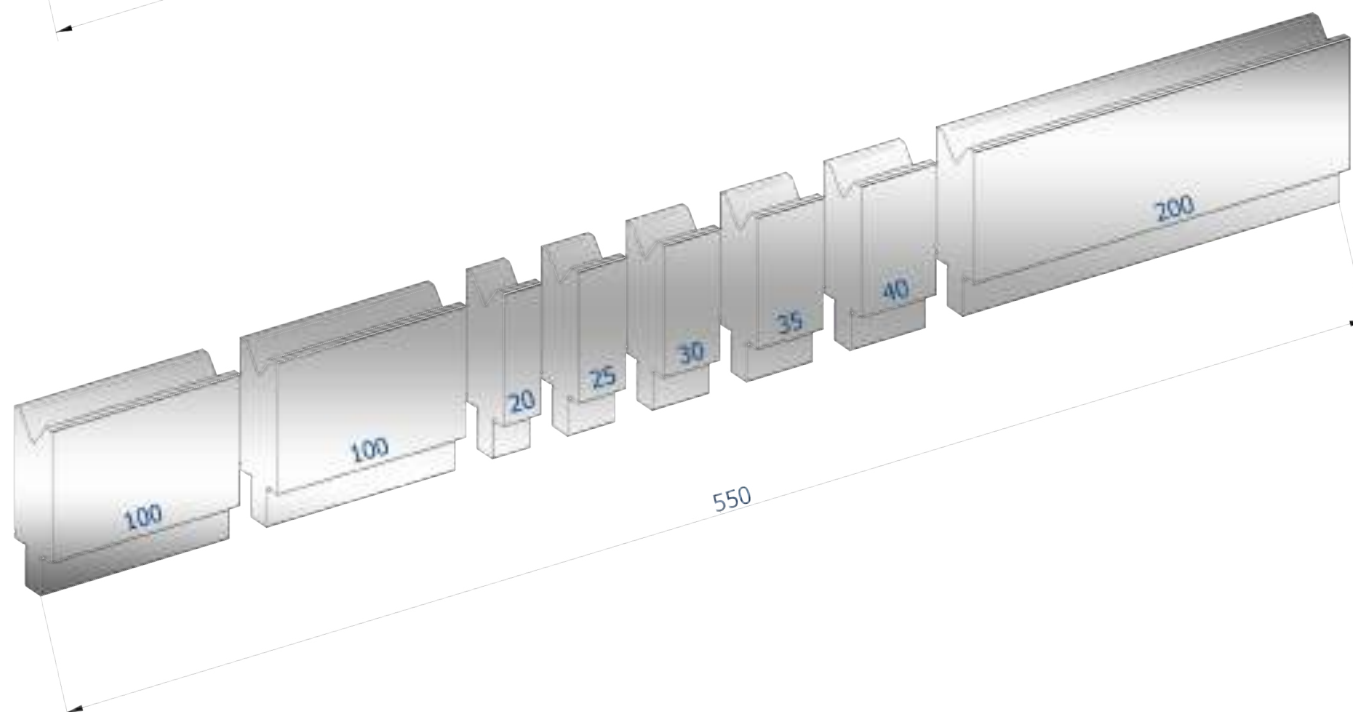
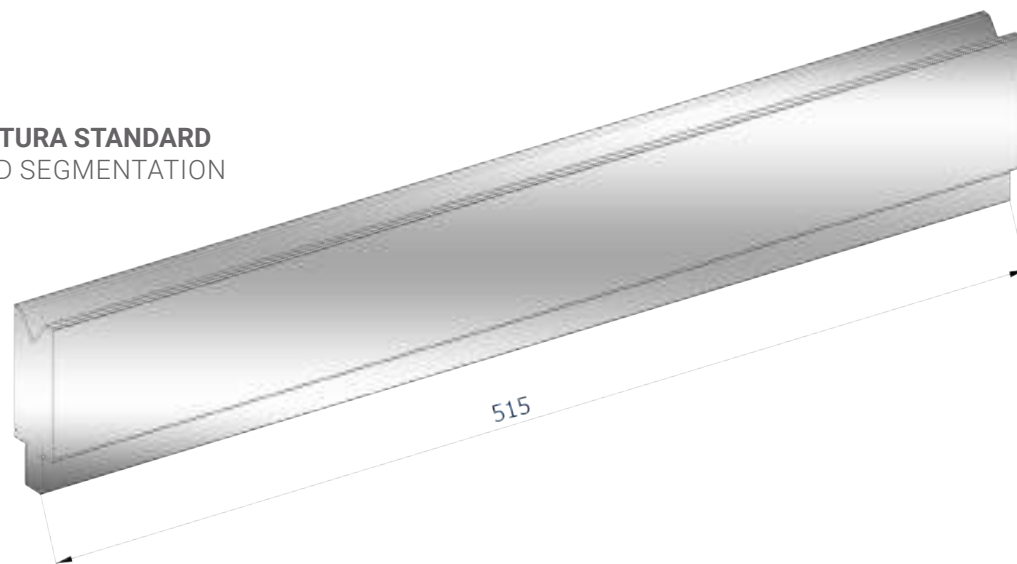





TAGLI A RICHIESTA
SPECIAL SEGMENTATION

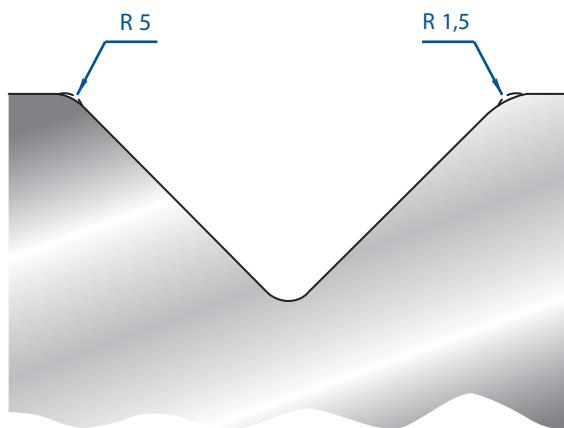

MODIFICA RAGGIO
RADIUS MODIFICATION

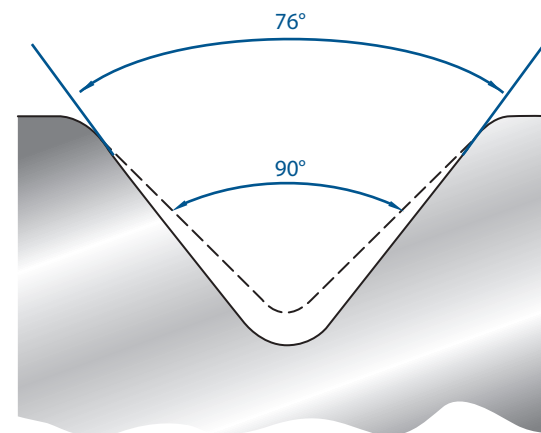

MODIFICA ANGOLO
ANGLE MODIFICATION



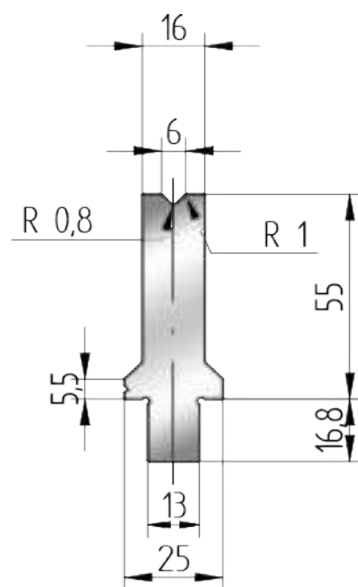

3250

Mat = 42CrMo4
bonificato / tempered

Max T/m = 120

α = 86°

515 mm	4,7 kg
550 mm FRAZ. / SECT.	5 kg

WILA
STYLE



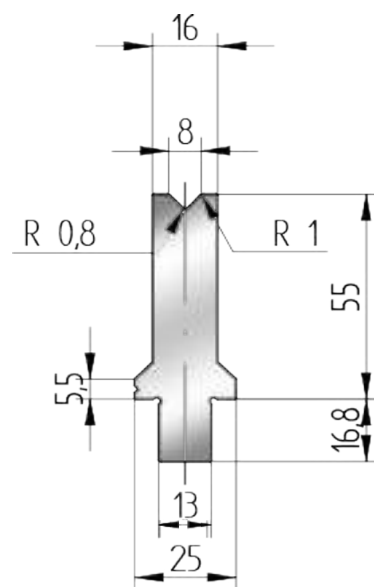

3251

Mat = 42CrMo4
bonificato / tempered

Max T/m = 120

α = 86°

515 mm	4,6 kg
550 mm FRAZ. / SECT.	4,9 kg



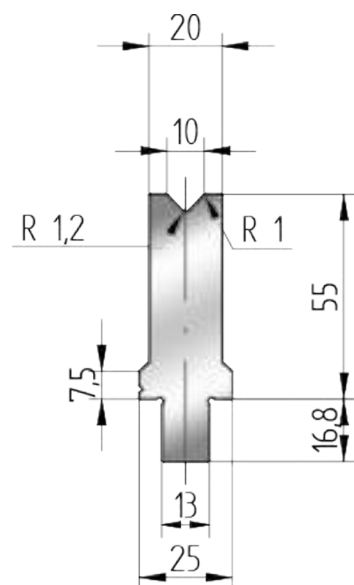

3252

Mat = 42CrMo4
bonificato / tempered

Max T/m = 120

α = 86°

515 mm	5,4 kg
550 mm FRAZ. / SECT.	5,7 kg



WILA
STYLE



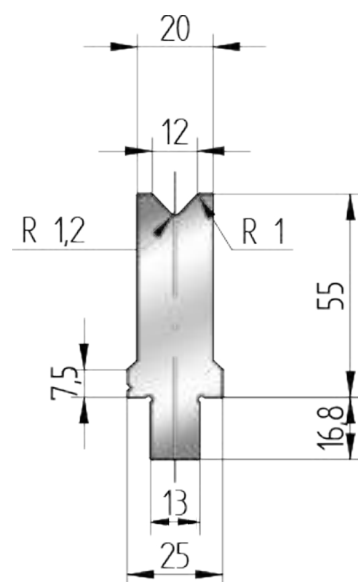

3253

Mat = 42CrMo4
bonificato / tempered

Max T/m = 120

α = 86°

515 mm	5,3 kg
550 mm FRAZ. / SECT.	5,7 kg



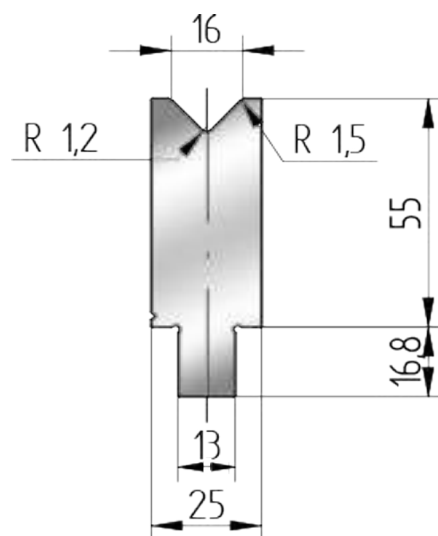

3254

Mat = 42CrMo4
bonificato / tempered

Max T/m = 120

α = 86°

515 mm	6,1 kg
550 mm FRAZ. / SECT.	6,6 kg

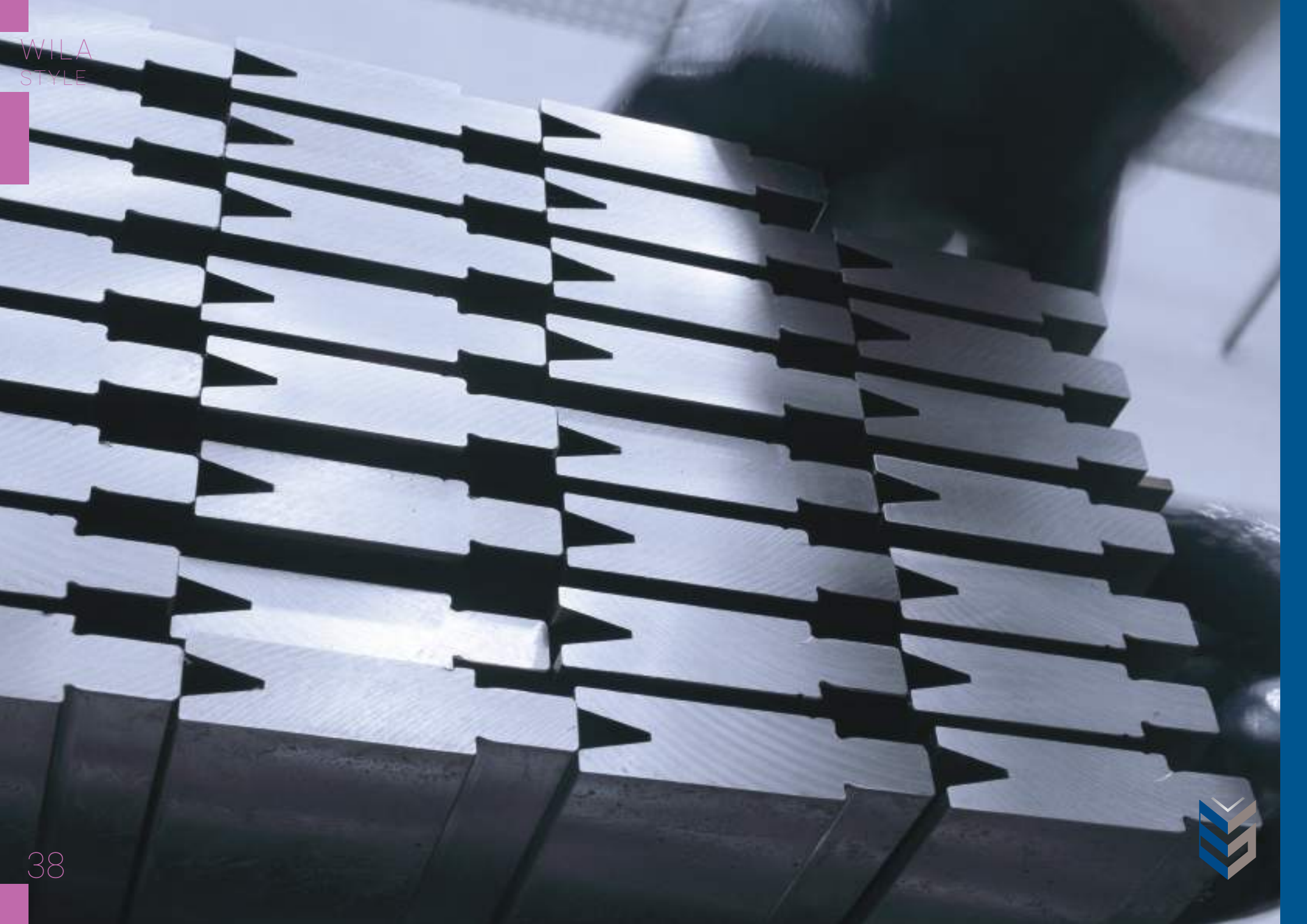

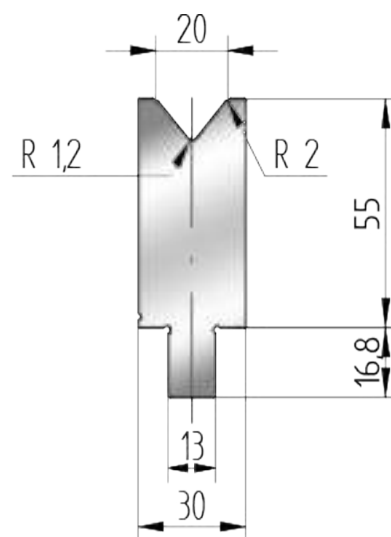

3255

Mat = 42CrMo4
bonificato / tempered

Max T/m = 120

α = 86°

515 mm	7,1 kg
550 mm FRAZ. / SECT.	7,7 kg



WILA
STYLE



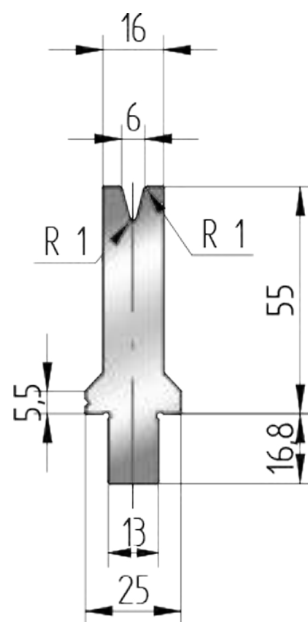

3260

Mat = 42CrMo4
bonificato / tempered

Max T/m = 25

α = 30°

515 mm	4,6 kg
550 mm FRAZ. / SECT.	4,9 kg

WILA
STYLE



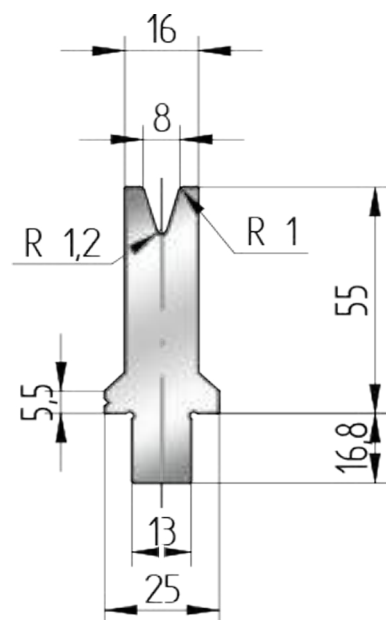

3261

Mat = 42CrMo4
bonificato / tempered

Max T/m = 25

α = 30°

515 mm	4,5 kg
550 mm FRAZ. / SECT.	4,8 kg



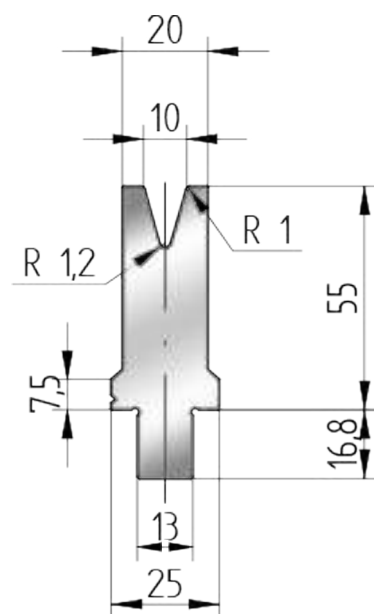

3262

Mat = 42CrMo4
bonificato / tempered

Max T/m = 20

α = 30°

515 mm	5,1 kg
550 mm FRAZ. / SECT.	5,5 kg

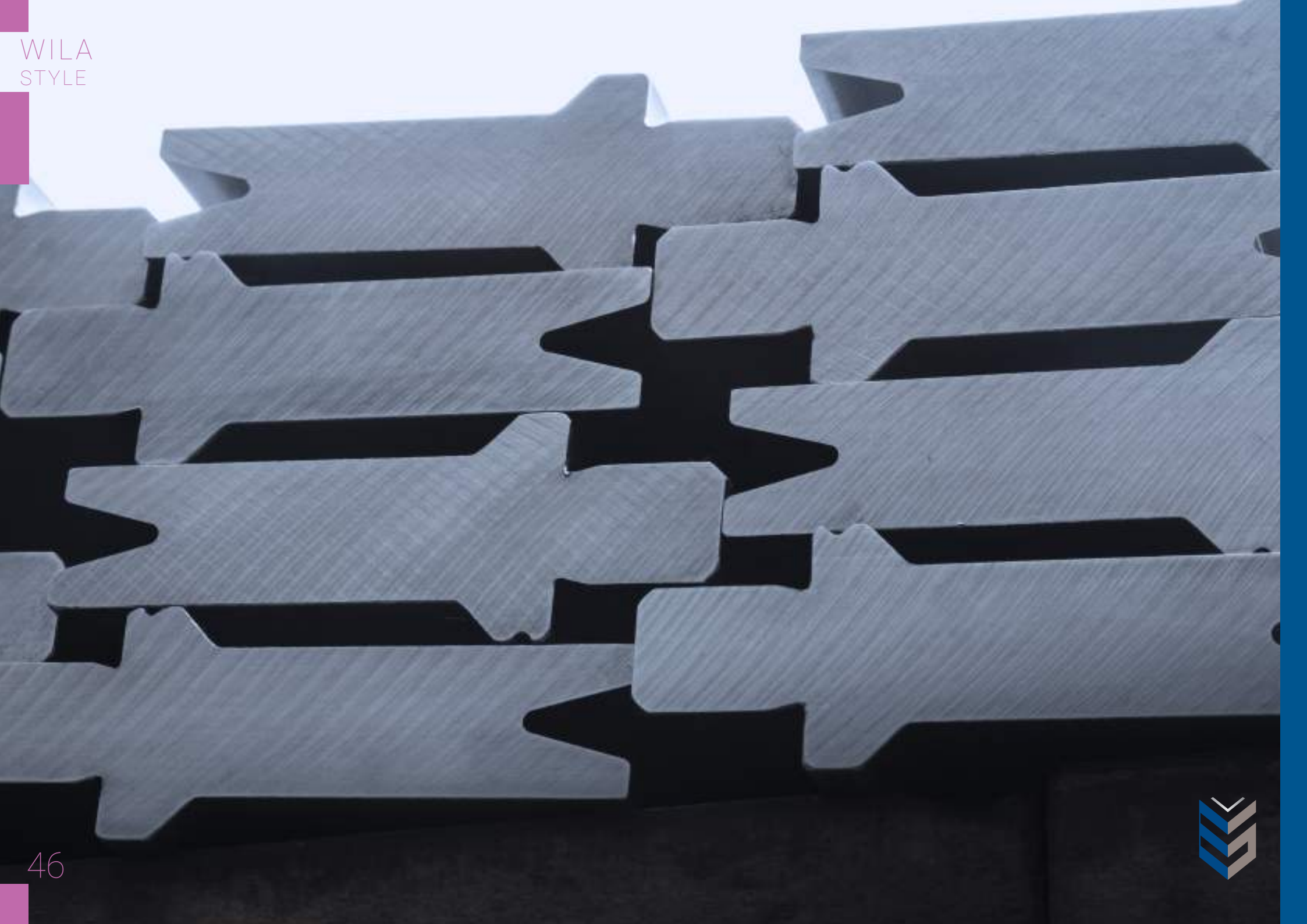

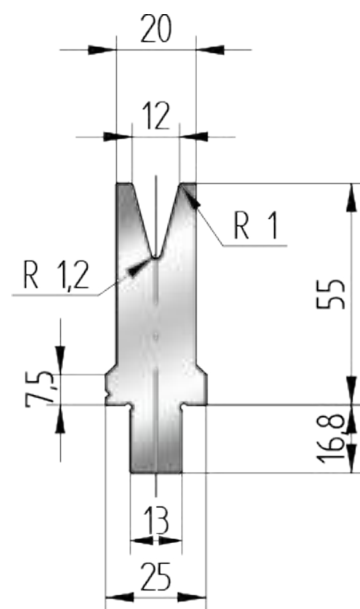

3263

Mat = 42CrMo4

bonificato / tempered

Max T/m = 20

α = 30°

515 mm	5 kg
550 mm FRAZ. / SECT.	5,3 kg

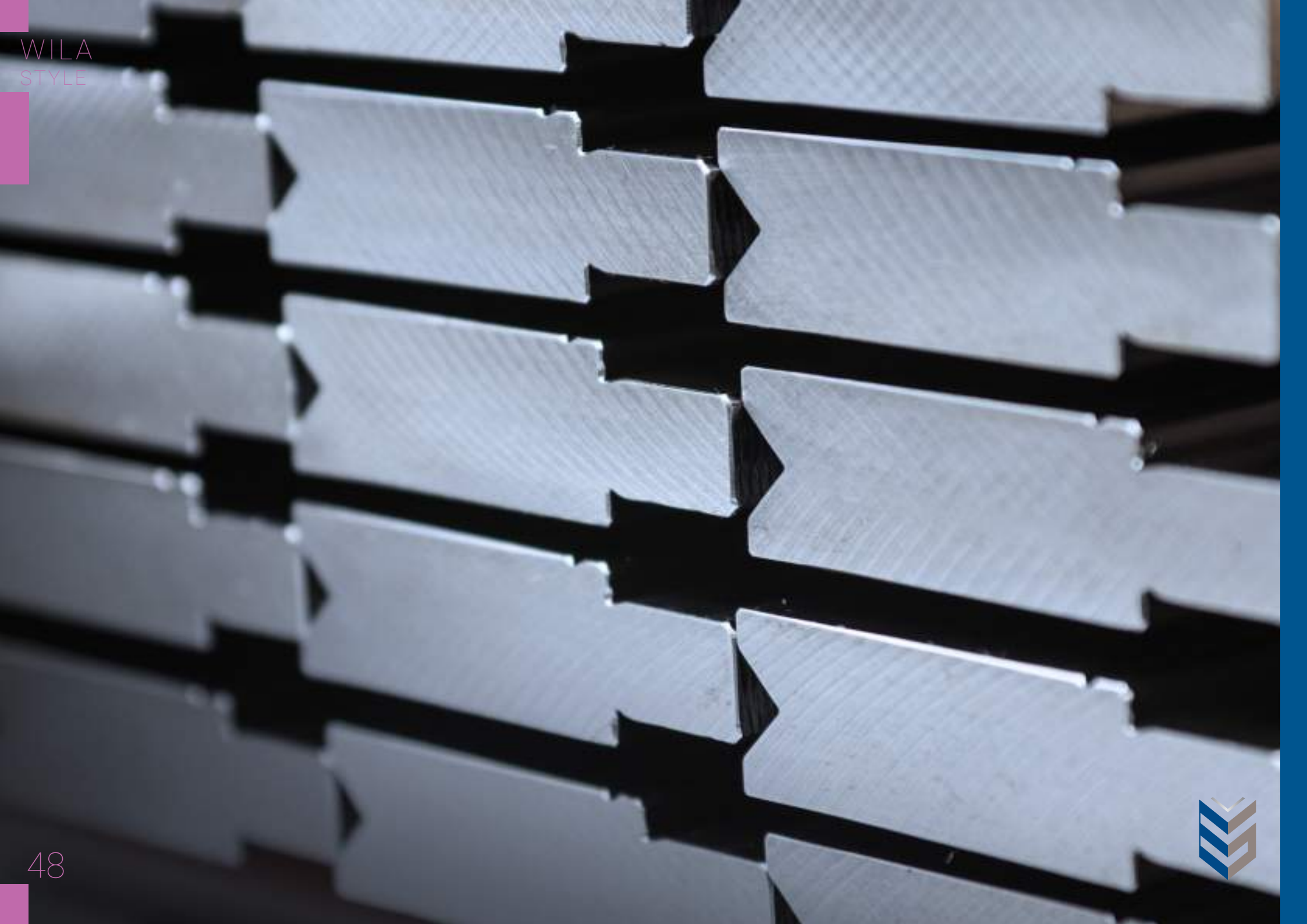

WILA
STYLE



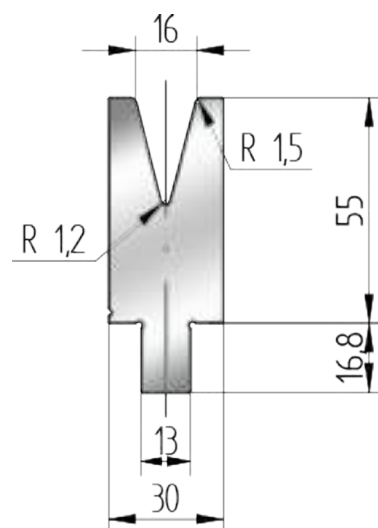

3264

Mat = 42CrMo4
bonificato / tempered

Max T/m = 20

α = 30°

515 mm	6,6 kg
550 mm FRAZ. / SECT.	7 kg

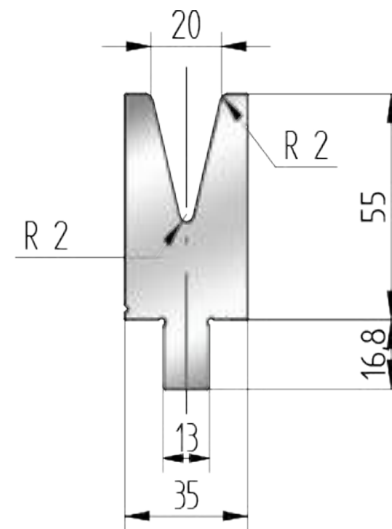

3265

Mat = 42CrMo4
bonificato / tempered
Max T/m = 30
 α = 30°

515 mm	7,2 kg
550 mm FRAZ. / SECT.	7,7 kg





EUROSTAMP TOOLING
the Italian excellence



Eurostamp srl

sede di produzione / production site
uffici commerciali / sales office

Via A. Borotti 9/11
29121 Piacenza (Italy)
Tel. +39 0523 489 954
Tel. +39 0523 499 254
Fax +39 0523 400 490
info@eurostampsrl.it

www.eurostampsrl.it